

Operating Manual

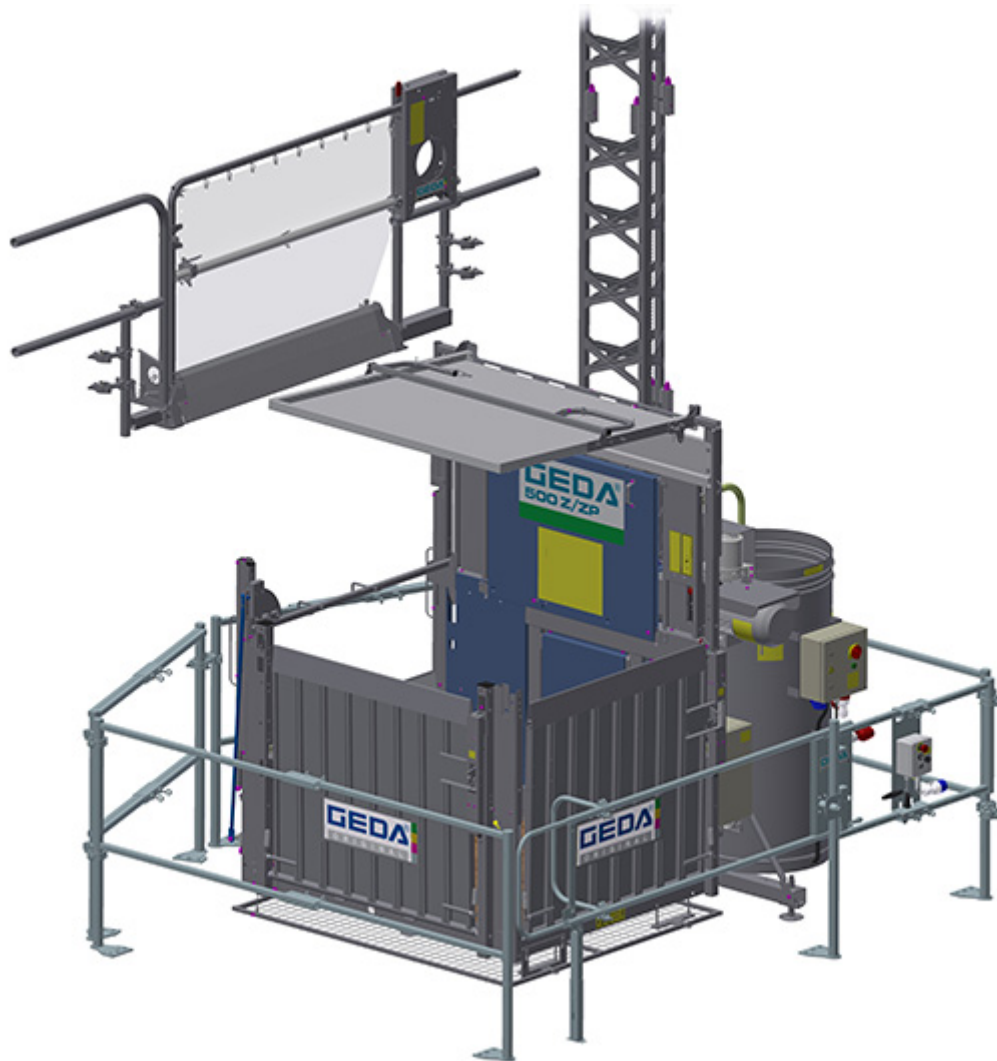

GEDA[®]
500 Z/ZP 2

Construction Hoist/Transport Platform

For passengers and materials

Original Operating Manual





EU Declaration of Conformity

The manufacturer:

GEDA-Dechentreiter GmbH & Co. KG
Mertinger Strasse 60
86663 Asbach-Bäumenheim

hereby declares that the machine

Designation:	Construction Hoist / Transport Platform (for temporary use on construction sites by authorised persons)		
Type:	GEDA500 Z/ZP 2	Serial number:	55640
		starting from:	05380
Type:	GEDA500 ZP/1000 Z	Serial number:	62750
		starting from:	05380

Manufacturing number: 05T...

Year of construction: Refer to name plate on the machine

is in compliance with all pertinent provisions of the following directives at the time of being put on the market.

<u>Directives:</u>	<u>Conformity evaluation procedures applied:</u>
2006/42/EU Machinery Directive	Appendix IX
2014/35/EU Low Voltage Directive	Appendix IV
2014/30/EU EMC Directive	Appendix II
2000/14/EU Noise Emissions Directive	Appendix V

Applied (harmonised) standards:

EN ISO 12100:2010, EN 60204-1/32:2018, EN 16719:2014

EC Type test certification procedure:

Type test certification

EC MRL 271/1

European notified test site

0036

TÜV SÜD Industrie Service GmbH
Westendstrasse 199
80686 Munich

This EU conformity declaration becomes null and void if any changes are made to the aforementioned machine that have not been authorised by the manufacturer. The authorised representative for technical documentation is the signatory. For address refer to manufacturer.

Asbach-Bäumenheim
Date 07/03/2018

Johann Sailer
CEO GEDA-Dechentreiter GmbH & Co. KG

Table of contents

1	General information	9
1.1	Information on the operating manual	9
1.2	Abbreviations	11
1.3	Identification data	12
1.4	Manufacturer's name and address	13
1.5	Information about the author and industrial property rights	14
1.6	Patents	14
1.7	Instructions for the operating company	14
1.8	Intended use	16
1.8.1	Assembly, service/maintenance specialist	18
1.8.2	Operating personnel	18
1.8.3	Improper use	18
2	General safety information	19
2.1	Residual risks	19
2.2	Safety instructions for operating personnel	20
2.3	Safety instructions for transport	21
2.4	Safety instructions for operation	22
2.5	Safety instructions for maintenance and troubleshooting	23
2.6	Safety when working on the electric system	25
3	Technical data	26
3.1	Operating and environmental conditions	26
3.2	Emissions	27
3.3	Tightening torques	27
3.4	Electrical connected loads	28
3.5	Speeds	29
3.6	Heights	29
3.7	Mast	30
3.8	Load capacity, dimensions and weights	33
3.8.1	Platform A	34
3.8.2	Platform B	36
3.8.3	Platform C	38
3.8.4	Platform SL	41
3.8.5	Platform 500 ZP/1000 Z 2	43
4	Operation	45
4.1	Safety during operation	45
4.1.1	Special safety instructions for operation as a material hoist	46
4.1.2	Special safety instructions for operation as a transport platform	46
4.2	Commissioning	47
4.2.1	Safety check before starting work	49
4.3	Operation/function	50
4.3.1	Securing the lowest stop position (ground station)	51
4.3.1.1	Cordon	52
4.3.1.2	1.10 m base enclosure with barrier (option)	53
4.3.1.3	Sliding door for 2.00 m base enclosure (option)	54
4.3.2	Platform access at the ground station	58
4.3.2.1	Loading door / Ramp	58

4.3.3	Platform access landing level	61
4.3.3.1	Barrier with mechanical lock	61
4.3.3.2	Barrier with electromagnetic lock	63
4.3.4	Securing loading and unloading points	65
4.3.4.1	"Standard/Standard Basic" landing level safety gate	65
4.3.4.2	"Comfort" landing level safety gate	67
4.3.4.3	"VARIO" landing level safety gate	69
4.3.5	Controls	71
4.3.5.1	Functional description	71
4.3.5.2	Use as a construction hoist (external control)	75
4.3.5.3	Operation as transport platform (platform control)	81
4.3.6	Controls for special operation	84
4.3.6.1	Operation for assembly	84
4.3.6.2	Drop test control	86
4.3.7	Emergency shutdown	87
4.4	Interrupting work – end of work	88
4.5	Equipment	89
4.5.1	Roofs	89
4.5.2	Assembly plank	91
4.5.3	Overrun and cable protection	92
4.5.4	Document and tool box	93
4.5.5	Operating hours counter	94
4.6	Accessories	95
4.6.1	Underrun protection	95
4.6.2	Cable bin cover	97
4.6.3	Cold package	97
4.6.4	Mast assembly aid	98
4.6.5	Single axle trailer	99
5	Malfunctions – diagnosis – repair	100
5.1	Diagnostic system	100
5.2	Fault table	102
5.3	Rectify fault	104
5.3.1	Motor is not delivering full power	104
5.3.2	Platform has travelled too high	104
5.3.3	Platform moved too low	104
5.3.4	Overload detection device has triggered	106
5.3.5	Safety gear has triggered	107
5.4	Retrieving the platform	109
5.4.1	Basic conduct in the event of a rescue/malfunction	109
5.4.2	Rescue action plan	110
5.5	Repair	113
6	Disposal	114

Table of figures

Fig. 1: UNI-X-MAST	30
Fig. 2: UNI-Mast	30
Fig. 3: Anchor diagram	31
Fig. 4: Platform A	34
Fig. 5: Required space platform A	35
Fig. 6: Platform B	36
Fig. 7: Required space platform B	37
Fig. 8: Platform C	38
Fig. 9: Required space platform C loading B-side	39
Fig. 10: Required space platform C loading C-side	40
Fig. 11: Platform SL	41
Fig. 12: Required space platform SL	42
Fig. 13: Ground station switch box	47
Fig. 14: Selector switch for operating mode, ready for operation	48
Fig. 15: Overview	50
Fig. 16: Cordon	52
Fig. 17: 1.10 m base enclosure with barrier	53
Fig. 18: Sliding door for ground base enclosure	54
Fig. 19: Unlocking the sliding door lock	55
Fig. 20: Opening the sliding door	55
Fig. 21: Closing the sliding door	55
Fig. 22: Sliding door for base enclosure open	56
Fig. 23: Emergency release for sliding door from outside	56
Fig. 24: Door lock unlocked	57
Fig. 25: Door lock locked	57
Fig. 26: Locking the loading door/ramp	58
Fig. 27: Platform with front ramp	59
Fig. 28: Platform with loading door	59
Fig. 29: Emergency release for ramp/loading door	60
Fig. 30: Platform access landing level	61
Fig. 31: Barrier with mechanical lock	61
Fig. 32: Opening barrier with mechanical lock	62
Fig. 33: Closing barrier with mechanical lock	62
Fig. 34: Barrier with electromagnetic lock	63
Fig. 35: Opening/closing the barrier with electromechanical lock	63
Fig. 36: Emergency release of the barrier with electromechanical lock	64
Fig. 37: Standard landing level safety gate no. 01217/01268	65
Fig. 38: "Standard" landing level safety gate closed (tarpaulin)	66
Fig. 39: Opening/closing the "Standard" landing level safety gate	66
Fig. 40: "Comfort" landing level safety gate no. 01212	67
Fig. 41: "Comfort" landing level safety gate closed (tarpaulin)	67
Fig. 42: "Comfort" landing level safety gate closed (perforated plate)	68
Fig. 43: Opening/closing the "Comfort" landing level safety gate	68
Fig. 44: "VARIO" landing level safety gate no. 68000	69
Fig. 45: Opening/closing the "VARIO" landing level safety gate	69
Fig. 46: Emergency unlocking of the landing level door	70
Fig. 47: Actuating the external control	75

Fig. 48: Ground control/manual control (position I)	76
Fig. 49: Ground control for enclosure (MANUAL)	76
Fig. 50: Ground control/manual control (position II)	78
Fig. 51: Ground control for enclosure (AUTOMATIC)	78
Fig. 52: Electric module for landing level safety gate	80
Fig. 53: Activating the platform control	81
Fig. 54: Selector switch for operating mode, assembly	84
Fig. 55: Platform control for assembly	85
Fig. 56: Drop test control	86
Fig. 57: EMERGENCY STOP button	87
Fig. 58 Main switch secured	88
Fig. 59: Folding roof	89
Fig. 60: Roof with assembly opening	90
Fig. 61: Assembly plank	91
Fig. 62: Overrun and cable protection	92
Fig. 63: Document box	93
Fig. 64: Operating hours counter	94
Fig. 65: Underrun protection	95
Fig. 66: Underrun protection platform SL	96
Fig. 67: Cable bin cover	97
Fig. 68: Cold package	97
Fig. 69: Lifting, positioning of mast parts	98
Fig. 70: Single axle trailer	99
Fig. 71: Diagnostic system	100
Fig. 72: Operating the drop test control	105
Fig. 73: Overload indicator	106
Fig. 74: Dummy plug for drop test control	107
Fig. 75: Drop test control	107
Fig. 76: Safety gear with limit switch	108
Fig. 77: Platform control/transport platform operation	110
Fig. 78: Mount for brake release lever	111
Fig. 79: Pulling on the brake release lever	111

1 General information

1.1 Information on the operating manual

This operating manual is an essential aid to operating the machine **successfully and hazard-free** (refer to chapter 2.1 Residual risks).

This operating manual contains important instructions on how to operate the machine **safely, correctly and efficiently**. Compliance with these instructions helps to avoid hazards and increases the reliability and service life of the machine.

The operating manual must be **available at the machine at all times** and must be read and applied by every person commissioned to work on/with the machine, e.g.:

- operation, fault elimination during work, disposal of operating materials and auxiliary supplies,
- assembly, maintenance (servicing, general maintenance, repair) and/or transport.



You will come across a series of illustrations and symbols while reading this manual. These are intended to help you navigate and understand this manual. The different meanings are explained below.

Text format	Meaning
Bold type	Emphasises particularly important words/sections
• List	Identifies lists level 1
- List	Identifies lists level 2
(brackets)	Item numbers
➤ Task instruction	Task instructions for personnel. Always given in chronological order

Images

The illustrations used refer to a specific machine type. They may only constitute a schematic representation of other machine types. The fundamental function and operation are not affected by this.

The structural elements in this operating manual appear as follows and have the following meaning:

⚠ DANGER	
	<p>Type and source of the hazard: Danger to life Consequence: Death/serious injury Probability: imminent</p> <p>➤ Measure for preventing the hazard</p>
⚠ WARNING	
	<p>Type and source: Risk of injury Consequence: Serious injury Probability: possible</p> <p>➤ Measure for avoiding</p>
⚠ CAUTION	
	<p>Type and source: Risk of injury Consequence: Minor injury Probability: possible</p> <p>➤ Measure for avoiding</p>
ATTENTION	
<p>Type and source: Damage to the machine Consequence: Property damage Probability: possible</p> <p>➤ Measure for preventing the damage</p>	
Safe working	
<p>Type and source: Failure to comply with health and safety regulations Consequence: Risk for life and limb Probability: possible</p> <p>➤ Observe these instructions and proceed with caution.</p>	



Indicates information on using the machine economically or instructions for correct working procedures.

1.2 Abbreviations

The following abbreviations may be used in the manual.

Abbreviation:		Abbreviation:	
Max.	maximum	Fig.	figure
min.	minimum	Nm	Newton metre
Min.	minutes	km/h	kilometres per hour
etc.	et cetera	mph	miles per hour
		incl.	including
e.g.	for example		
ml	Millilitre	i.e.	that is
mm	Millimetre		
°C	degrees Celsius	RH	relative humidity
°F	degrees Fahrenheit	approx.	approximately
ft.	feet	∅	diameter
ft/m	feet per minute	®	registered trademark
m/min	metres per minute	©	copyright
		TM	trademark
		%	per cent
lbs.	pounds	‰	per mil
lbf.-ft	pounds per feet	L _{PA}	sound pressure level
kg	kilogramme	L _{WA}	noise capacity level
L	litre	>	greater than
gal.	gallons	<	less than
kip.	kilopound	±	plus/minus

1.3 Identification data

Machine type:	GEDA 500 ZP/1000 Z 2
Serial number:	62750 _____
Factory number:	05T... _____
Machine type:	GEDA500 Z/ZP 2
Serial number:	55640 _____
Manufacturing number:	05T... _____
Year of construction:	Refer to name plate
Documentation version:	2019-05

1.4 Manufacturer's name and address

GEDA-Dechentreiter GmbH & Co. KG
 Mertinger Strasse 60
 86663 Asbach-Bäumenheim
 Tel.: +49 (0)9 06 / 98 09-0
 Fax: +49 (0)9 06 / 98 09-50
 E-Mail: info@geda.de
 Web: www.geda.de

Representatives of the manufacturer

Bergkamen subsidiary	Gera subsidiary
GEDA-Dechentreiter GmbH & Co. KG Northwest Subsidiary Marie-Curie-Strasse 11 59192 Bergkamen-Rünthe Tel. +49(0)2389 9874-32 Fax. +49(0)2389 9874-33	GEDA-Dechentreiter GmbH & Co. KG Eastern Subsidiary Ernst-M.-Jahr Strasse 5 07552 Gera Tel. +49(0)365 55280-0 Fax. +49(0)365 55280-29
U.S. subsidiary	Russia subsidiary
GEDA USA, LLC 1151 Butler Road League City (Houston), TX 77573 Tel. +1(713) 621 7272 Fax. +1(713) 621 7279 Web: www.gedausa.com	GEDA RUS, LLC Tsentralnaya str., build. 3/1, office H-208 141031 Nagornoye, Moscow region Russian Federation Tel. +7(495) 150-42-67 Fax. +7(495) 150-43-67 Web: www.geda-ru.com
Turkey Subsidiary	Korea Subsidiary
GEDA MAJOR IS VE INSAAT MAKINALARI SAN. TIC. LTD. STI. Semsettin Günaltay Cad. No:224 A Blok K:2 D:5 Tüccarbası/Erenköy TR-34734 Istanbul/Türkiye Tel.: +90 (216) 478 2108 Fax: +90 (216) 467 3564 Web: www.geda.com.tr	GEDA KOREA 1708, (MetroDioVill Bldg., Singongdeok-dong) 199, Baekbeom-ro, Mapo-gu, Seoul 04195 Korea Tel.: +82 2 6383-7001 Fax: +82 2 6383-7009 Web: www.gedakorea.com

1.5 Information about the author and industrial property rights

All documents are protected within the terms of the copyright law. Dissemination and reproduction of documents (including parts thereof), as well as reuse or disclosure of their contents, are prohibited unless expressly permitted in writing.

The copyright and conditions of use of any software/user documentation from other manufacturers that may be included within the scope of delivery must be observed.

Violations are an offence and incur an obligation to pay compensation. All rights to exercise industrial property rights are reserved by GEDA.

1.6 Patents

Some components in our machines are protected by patent rights. To find out how to request information about these, refer to <http://www.geda.de/>.

1.7 Instructions for the operating company

This operating manual is an essential component of the machine. The operating company must ensure that operating personnel are **informed** about these guidelines.

The operating company must supplement the operating manual with **operating instructions** based on existing national regulations for accident prevention and for the **protection of the environment**, including information regarding supervisory and reporting duties that take account of company-related specifics, e.g. with reference to work organisation, work procedures and the personnel employed.

In addition to the mandatory **regulations for accident prevention and industrial safety** that apply both in the country of use and at the place of use, accepted professional rules for safe and competent working must also be observed.

The operating company must ensure that operating personnel wear **personal protective equipment** appropriate to the local conditions.

First aid equipment (first aid kit, etc.) must be kept within reach!

The operating company/user of the machine **must not make any changes, additions or modifications** to the machine that could impair safety without permission from the manufacturer! This also applies to installing and adjusting safety devices as well as welding on load-bearing components.

Any **replacement and wearing parts** that are used must correspond to the technical requirements stipulated by GEDA. This is ensured with **original replacement parts**.

Only employ **qualified and/or trained personnel** for the tasks described in this manual.

The operating company clearly defines the responsibilities of the personnel for operation/installation/maintenance.

The operating company is obliged to instruct all people authorised to use the machine in the correct way to handle the machine based on their respective range of activities and responsibilities using practical exercises, before they use it for the first time.

This **training** must be documented and **repeated at regular intervals**.

The legally permissible minimum age must be observed!

1.8 Intended use



The 500 Z/ZP 2 is suitable for temporary use at construction sites. Any other locations or intended uses require written approval from the manufacturer.

The 500 Z/ZP 2 is a construction material hoist and a transport platform that is temporarily erected and

- which may only be operated after the landing level safety gates are installed at each transfer point to the building or scaffolding
- which may only be operated at a wind speed of up to 72 km/h (20 m/sec. wind force 7-8 according to the Beaufort scale)
 - which must have its platform parked on the ground and taken out of operation at higher wind speeds.

As a construction material hoist

- which is intended exclusively for putting up scaffolding and for transporting items and materials during construction work
- which may only be operated from outside the cordoned-off and signposted hazard area using the ground control and/or operated from the electric modules on the landing level safety gates

As a transport platform for carrying persons

- for transporting materials and **max. 5 persons** which can exit the platform at installed and secured transition points
- which may only be used by trained personnel (platform operator) at construction sites
- which can only be operated from the platform with dead man's control; (operation is not possible from other control locations)
- which can be stopped at any position (e.g. to unload bulky components over the base enclosure)

Transport platform equipped for operation as per EN 16719

- **roof** over the complete platform (see chapter 4.5.1).
- **landing level platform access** (see chapter 4.3.3)
 - as a barrier with electromagnetic lock
 - as a barrier with mechanical lock (**two** separate actions), or
- with **underrun protection** installed under the platform [option] (chapter 4.6.1), a **cordon** is sufficient for securing the ground station (chapter 4.3.1.1) to protect persons and the machine.

or

- a **base enclosure** [option]
 - 1.10 m with limit-switch monitored barrier (see chapter 4.3.1.2) or
 - 2.00 m with sliding door (see chapter 4.3.1.3)
- **Landing level safety gate** closed (see chapter 4.3.4)

As a mast climbing platform

- which is designed for transporting material and a **max. of 5 persons** who can carry out tasks from the platform
- which can only be operated from the platform with dead man's control; operation is not possible from other control locations

The instructions in chapter 3 Technical data must be observed and adhered to.

Any other use or any use going beyond this is not considered proper use.

The operating company/user of the machine is solely liable for any damage resulting from this. This applies equally to any unauthorised changes to the machine.

1.8.1 **Assembly, service/maintenance specialist**

A person who, due to qualified professional education, training and experience, is able to recognise risks and potential hazards during assembly/maintenance/repair work on the machine and subcomponents and can rectify these by introducing appropriate measures.

1.8.2 **Operating personnel**

The machine may only be operated by persons who, based on their training, knowledge and practical experience, can ensure proper handling.

These persons must

- have been appointed by the operating company
- have been appropriately instructed and informed about the risks
- be familiar with the operating manual
- observe national regulations.

1.8.3 **Improper use**

The 500 Z/ZP 2

- is not designed for permanent installation
- must not be set up to be free-standing (without anchoring)
- must not be operated by persons without instruction on the machine or by children The persons must be familiar with the operating manual.

Consequences of improper use of the machine

- Danger to life and limb of the user or a third party.
- Damage to the machine and other objects.

2 General safety information

The machine has been designed and built according to the state of the art and recognised safety rules.

Nevertheless, hazards for personnel or third parties and/or damage to machinery and other tangible assets can occur during use, e.g. if the machine:

- is operated by untrained or uninstructed personnel,
- is not used for the intended purpose,
- is assembled, operated and serviced inappropriately.

Attached notices and warning signs must be observed!

Consequences of failure to comply with safety instructions

Failure to comply with safety instructions can result in hazards for personnel as well as for the environment and the machine. Failure to comply can lead to any claims for damages becoming invalid.

2.1 Residual risks

Residual risks remain from handling the machinery even when all safety conditions are complied with.

Anyone who works on and with the machine must be aware of these hazards and follow instructions that prevent these residual risks leading to accidents or damage.

- Do not remove any safety labels; replace any safety instructions that have become illegible.
- Hazard from improperly secured loads falling.
- Hazard when entering and leaving the platform.
- Hazard from damage to the mast sections, anchors or base unit.
- Hazard when working on the electrical system.
- Hazard from malfunctions in the control system.
- Hazards from uncoordinated working practices.
- Risk to persons by operating the platform with no cordoned-off area/base enclosure.
- Hazard from high wind speeds > 72 km/h.

2.2 Safety instructions for operating personnel

The operating manual must be kept within reach at all times **at the location where the machine is used.**

The machine may only be used in a technically flawless condition, **in accordance with the intended use, in a safety conscious manner, with awareness for the hazards** and in compliance with this operating manual! In particular, faults that could impair safety must be eliminated immediately!

In addition, the machine may only be operated when all **safety devices are installed and functioning!**

Check the machine for externally identifiable damage and defects **at least once each working day!** Immediately report any changes (including changes to the operating behaviour) to the office/person in charge. If necessary, shut down and secure the machine immediately! The **responsibilities** for different jobs within the context of operation and maintenance of the machine must be clearly defined and adhered to. This is the only way to avoid mistakes, especially in hazardous situations.

The relevant **rules for the prevention of accidents**, as well as other, generally recognised health and safety rules must be adhered to.

The hoist operator is obligated to wear **personal protective equipment** appropriate to the local conditions.

Switch-on and shut-down procedures, including emergency shut-down, must be observed in accordance with the operating manual for all work that affects operation and for conversions and adjustments to the machine and its safety devices.

2.3 Safety instructions for transport

Immediately report **transport damage** and/or **missing parts** to the supplier.

During transport tasks, wear a **safety helmet, safety shoes and protective gloves!**

Never walk below suspended loads!

Only use **appropriate, standardised and tested lifting devices** (forklifts, cranes) and load attachment gear (lifting beam, round slings, lifting straps, rope slings, chains) for transport at the assembly site.

When selecting lifting and slinging equipment, always take into account the **maximum suspended loads!**

Dimensions and weights can be found in chapter 3 Technical data.

Only load and transport **the carefully dismantled, packed and lashed machine.**

Always ensure that the machine is transported **without being knocked or jolted**. Ensure that the machine is stable during transport. Support the platform before strapping it down for transport.

Observe the **symbols on the packaging.**

Only attach gear to the **designated attachment points.**

Always **secure transported loads against falling or tipping over!**

The machine must only be transported/installed on foundations with sufficient load capacity.

Ensure that stable balance is maintained when transporting with forklift trucks.

2.4 Safety instructions for operation

Only operate the machine in accordance with the operating manual, **when it is in full working order, and in a safety and hazard-conscious manner.**

If **work is interrupted, switch the machine off at the main switch** and secure it with a padlock against being switched on again.

Fundamentally, the machine must be **secured against unauthorised use** (disconnect from power)!

In situations that present a **risk to the operating personnel** or the machine, shut down the machine by pressing the **EMERGENCY STOP** button.

No one is allowed to stand under the machine. Ensure that the hazard area is suitably cordoned off at the customer's site. (Install cordoned off area or base enclosure.)

The machine must not be used as steps or a climbing aid. Only use tested and stable steps/climbing aids. Keep steps/climbing aids free of dirt and soiling.

Protection to prevent persons from falling must be provided at loading heights above 2.0 m. (Install landing level safety gates.)

Move load platform down and shut down machine at wind speeds of >72 km/h. (Wind force 7-8, wind breaks branches off trees, makes walking very difficult)

All persons in the hoist must comply with the hoist operator's instructions. They must not lean out over the sides of the platform or step across material being transported.

2.5 Safety instructions for maintenance and troubleshooting

Operating personnel must be **informed** about how to carry out special work and repair work before starting.

Deadlines that are stipulated or stated in the maintenance manual for recurring **tests/inspections** must be adhered to.

The **maintenance area** must be **cordoned off** extensively as required! Before carrying out any maintenance work on the machine, always

- unload it,
- switch it off at the main switch.

All **maintenance and repair work** is only permitted with the **main switch turned off** or **with the mains plug disconnected**. Manual intervention while the machine is running can lead to serious injuries and is therefore prohibited. If it is necessary to **switch the machine on during** such work, this must only be done while **complying with special safety measures**.



For further instructions on maintenance, maintenance intervals and servicing, refer to the maintenance manual.

If the machine has been completely shut down for these tasks, it must be secured against being switched on unintentionally:

- Actuate the **EMERGENCY STOP** button
- **Lock** the **main switch** using a shackle lock and
- attach a **warning notice** to the switch box (main switch).

Any faults that could impair safety must be rectified immediately.

Workshop **equipment that is suitable for the specific work** is absolutely necessary for carrying out **maintenance and inspection work**. When carrying out maintenance tasks at greater heights, a fall protection system must be worn! Keep all handles, railings and the platform free from dirt and contamination.

When working below the platform, secure it using appropriate means (e.g. bolts, mast clamps)

Before starting service/repair tasks, **clean** any oil, operating fluids, contamination and maintenance products from the machine, paying special attention to connections and threaded connections. Do not use abrasive cleaning materials. **Screw connections that were released** during maintenance and inspection work must always be tightened again using the necessary **torques!**

Do not change, remove, bypass or bridge safety devices.

If it is necessary to dismantle safety devices during maintenance and repair work, the safety devices must be installed and checked immediately after completion of the maintenance and repair tasks!

Do not make any changes, additions or modifications to the machine. This also applies to the installation and adjustment of safety devices such as limit switches.

Immediately replace damaged or detached information and warning signs, as well as safety labels.

Ensure that operating and auxiliary materials, as well as replaced parts, are disposed of safely and in an environmentally friendly manner (see also Disposal).



The aforementioned safety measures also apply to troubleshooting.

2.6 Safety when working on the electric system

If there are **faults on the electrical system** of the machine, it must be **shut down immediately using the main switch** and secured with a padlock or the mains plug must be disconnected!

Work on the electrical equipment of the machine must only be carried out by **qualified electricians** working in accordance with electrical engineering regulations! Only professional electricians may access the electrical system of the machine and carry out work on them. **Always keep the switch boxes closed** whenever they are left unattended.

Never work on live parts! System parts on which inspection, maintenance or repair work is to be carried out must be **disconnected from the mains power**.

Operating equipment that has been disconnected must be secured against being switched back on unintentionally or automatically (lock away fuses, block isolating switches, etc.). The disconnected electrical components must first be tested to ensure they are voltage-free, then earthed, short-circuited and isolated from neighbouring live components.

If **tasks have to be carried out on live components** (only in exceptional circumstances), an additional person must be present to operate the **EMERGENCY STOP** button or main switch in the event of an emergency. Use only insulated tools!

During repairs, ensure that **design features** are not **modified** so that they have a negative influence on safety. (e.g. creeping distances, clearances and distances must not be reduced by insulation).

Fault-free **earthing** of the electrical system must be ensured by a **protective earth system**.

3 Technical data

3.1 Operating and environmental conditions

The machine may only be operated when the following operating and environmental conditions are adhered to:

- Storage in dry rooms, in order to prevent corrosion.
- No jolts or vibrations.
- No abrasive, corrosive substances.
- The machine must be protected against pest damage (insects, rodents, etc.).
- Before transport/storage, the machine must be cleaned and checked for signs of damage.

Temperature range:	minimum	- 20 °C
	maximum	+40 °C
Humidity (relative):		80 % RH
Wind speed:		
Operation/maintenance/repair	maximum	72 km/h
Assembly:	maximum	45 km/h

It may be necessary to cease or prohibit operation of the machine under extreme weather conditions, even if the operating and environmental conditions fall within the bounds of those stated. For example, if heavy frost and a storm occur together. In these cases, the operating company must provide appropriate regulations.

Do not use during storms (lightning)!

Atmosphere at the location of use during material transport

When transporting material, this must not lead to a concentration of abrasive/corrosive substances and of explosive fine dusts. If this cannot be safely excluded, the corrosion protection and/or the functional reliability of the electrical components must be checked at regular intervals and they should, if necessary, be replaced. Fine particulate matter must be removed.

Atmosphere at the location of use during passenger transport

The atmospheric composition on-site must be suitable for people to remain for longer periods in the area. In particular, a reduction in the oxygen concentration as a result of displacement or consumption must be prevented. The legal limit values for pollutant concentrations/aerosols and dust in the workplace must not be exceeded.

3.2 Emissions

Sound pressure level: < 78 L_{PA}

3.3 Tightening torques

Special mechanical screw connections with torque control

Mast - elements to one another		
Tightening torque		
150 Nm	110 lbf ft	
Width across flats (AF) 24 mm		
Mast pipes		
Tightening torque		
50 Nm	37 lbf ft	1 ½" clamps
100 Nm	74 lbf ft	2" clamps
Flange connection trolley/floor assembly platform		
Tightening torque		
700 Nm	516 lbf ft	Cheese-head screw M24
Width across flats (AF) 36 mm		

General mechanical fittings without torque control

Tightening torques (All details refer to screws with strength class 8.8)					
M8	25 Nm	18 lbf ft	M18	300 Nm	221 lbf ft
M10	49 Nm	36 lbf ft	M20	425 Nm	313 lbf ft
M12	86 Nm	63 lbf ft	M22	575 Nm	524 lbf ft
M14	135 Nm	100 lbf ft	M24	710 Nm	524 lbf ft
M16	210 Nm	159 lbf ft	M30	1445 Nm	1066 lbf ft

Electrical screw connections

Tightening torques					
M4	1.2 Nm	0.88 lbf ft	M12	15.5 Nm	11 lbf ft
M5	2 Nm	1.47 lbf ft	M16	30 Nm	22 lbf ft
M6	3 Nm	2.21 lbf ft	M20	52 Nm	38 lbf ft
M8	6 Nm	4.42 lbf ft	M24	80 Nm	59 lbf ft
M10	10 Nm	7.37 lbf ft	M30	150 Nm	110 lbf ft

3.4 Electrical connected loads

The customer must provide a building site main cabinet (complying with IEC 60439-4:2005) with fuse protection of the supply point of

- min. 3 x 16 A slow-to-blow and a
- Residual current circuit breaker (RCD) with a
- rated current of max. 0.03 A required.

Base unit

Operating voltage	400 V / 50 Hz / 3 x 16 A / 3 Ph
Protection rating	IP 54 (NEMA 3)

Drive 400 V / 50 Hz

Capacity	3.0 / 6.1 kW
Current consumption	7.5 / 13.8 A
Start-up current	approx. 60 A
Duty cycle	S3 (60%)
Motor brake	170 V DC, 0.3 A
Working socket (in the car)	230 V / 50 Hz, 6 A

3.5 Speeds

Lifting speed

Construction hoist
(External control) 24 m/min.

Transport platform
(Platform control) 12 m/min.

In the lower safety area
(0 - 2.0 m) 12 m/min.

Safety gear FV18

Triggering speed max. 33 m/min. (108 ft/min)

3.6 Heights

Height of the lower safety area approx. 2 m

Access height (threshold level): min. 0.32 m

Installed height (H): max. 100 m

Assembly site elevation:
(metres above sea level) max. 1000 m (3289')

3.7 Mast

UNI-X-MAST

Only original GEDA mast sections may be used!

UNI-X-MAST
(item no. 03350)

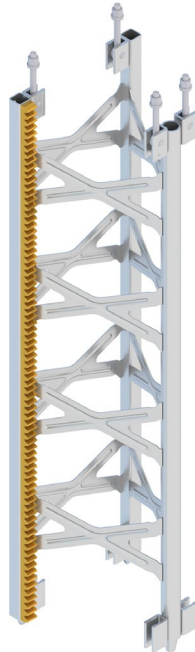

Fig. 1: UNI-X-MAST

Uni-Mast
(item no. 01150)



Fig. 2: UNI-Mast



If UNI-X-Mast parts UNI-Mast parts are installed together, only the anchoring spacings and anchoring forces for the Uni-Mast apply!

Length	1.5 m
Weight	40 kg
Tightening torque (connecting bolts)	150 Nm
Vertical distance trailing cable guide	≤ 6 m

⚠ DANGER	
	<p>Danger to life</p> <p>Limited overrun at the last mast bracket. Dimension W mast bracket to top track rollers approx. 0.5 m below the mast end.</p> <p>➤ max. 5 m 500 Z/ZP; 500 ZP P platform A / B / C / SL</p>

- W** = max. protruding mast length
during operation and assembly
- Z** = max. loading height above last anchor
- H** = max. installation height
- G** = max. vertical distance of the mast anchors
- E** = max. first mast anchor

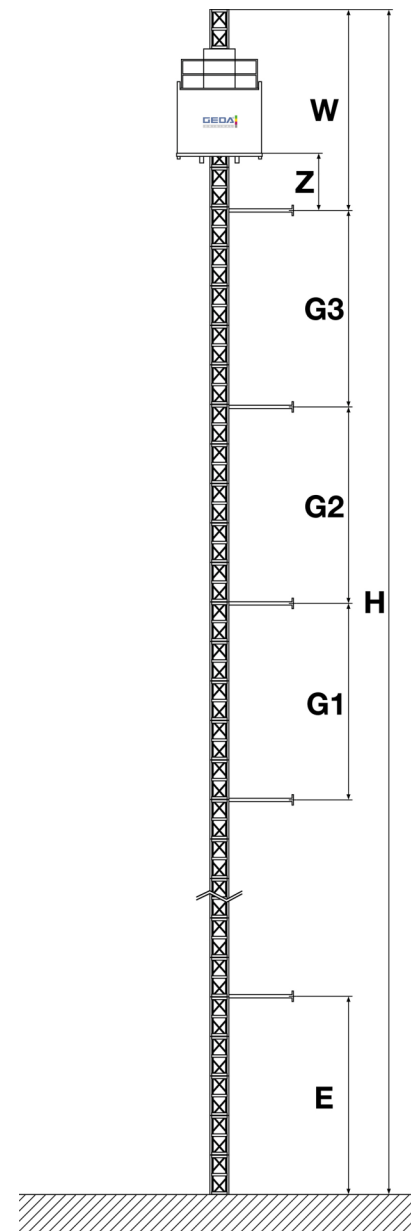

Fig. 3: Anchor diagram

W =	Operation:	
	Platform A, B, C, SL	5.0 m
	Assembly:	max. 7.50 m
Z =		W - 1.50 m
H =		100 m
G =		8 m
E =		4 m

Inclination of mast
for vertical installation

max. **installation height (H)**
500

in X and Y direction

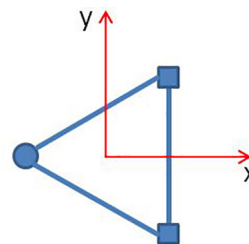

Example 1

Installed height = 50 m

$$\frac{50 \text{ m}}{500} = 0.1 \text{ m}$$

Example 2

Installed height = 100 m

$$\frac{100 \text{ m}}{500} = 0.2 \text{ m}$$



Check inclination during and following assembly using appropriate means.

During assembly, the maximum permitted distance between the car door and the landing level safety gate (see Assembly Manual) must be ensured.

3.8 Load capacity, dimensions and weights

Cable bin with trailing cable

	Weight
25 m lifting height	65 kg
50 m lifting height	80 kg
75 m lifting height	95 kg
100 m lifting height	110 kg

Assembly plank

Load capacity	120 kg
Weight	approx. 40 kg

Lifting beam

Load capacity	1700 kg
Weight	approx. 15 kg

Mast assembly aid

Load capacity	100 kg
Weight	approx. 20 kg







Installation of optional equipment (e.g. roof, underrun protection, assembly plank) increases the dead weight. The load capacity of the platform decreases accordingly!

3.8.1 Platform A



Fig. 4: Platform A

Load capacity

Construction hoist	max. 850 kg
Transport platform	max. 500 kg / 5 persons
	400 kg + 1 
	300 kg + 2 
	200 kg + 3 
	100 kg + 4 
	----- kg + 5 
Assembly up to the second mast tie	250 kg
Assembly from the second mast tie	500 kg

Dimensions/required space

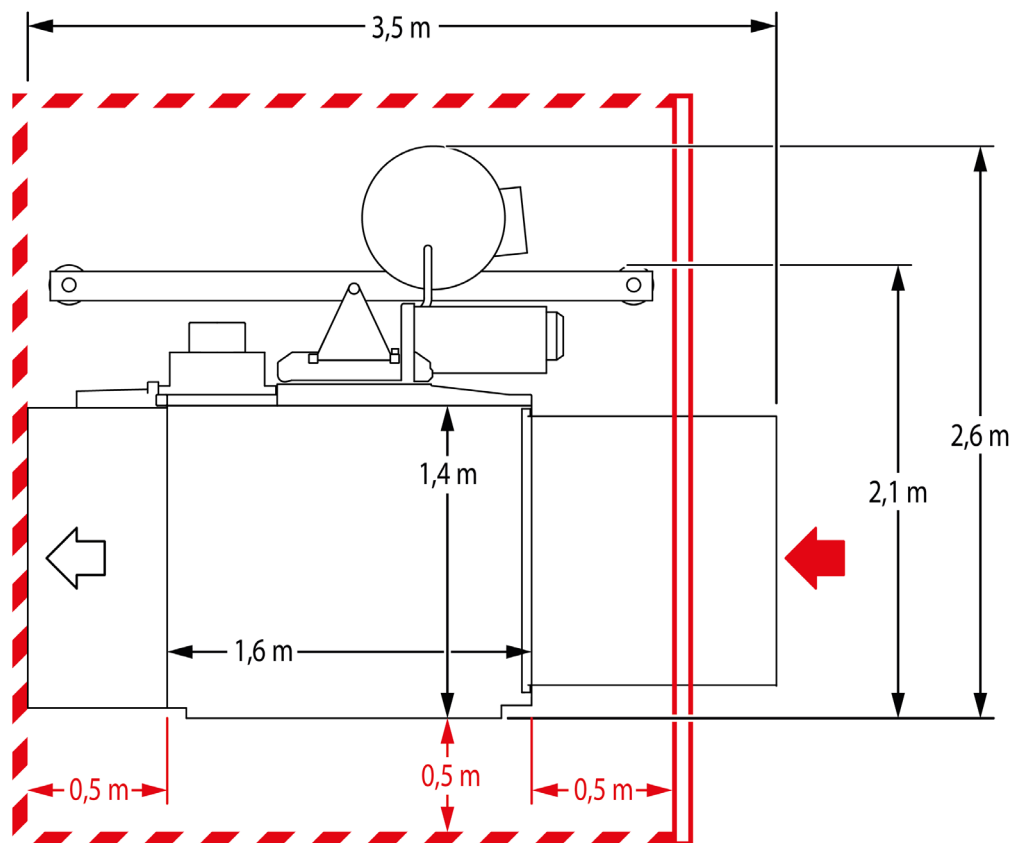

Fig. 5: Required space platform A

Height 2.3 m (2.5 m with roof)

Weights





Base unit with platform	825 kg
Roof	24 kg
Underrun protection	25 kg

3.8.2 Platform B



Fig. 6: Platform B

Load capacity

Construction hoist	max. 850 kg
Transport platform	max. 500 kg / 5 persons
	400 kg + 1 
	300 kg + 2 
	200 kg + 3 
	100 kg + 4 
	----- kg + 5 
Assembly up to the second mast tie	250 kg
Assembly from the second mast tie	500 kg

Dimensions/required space

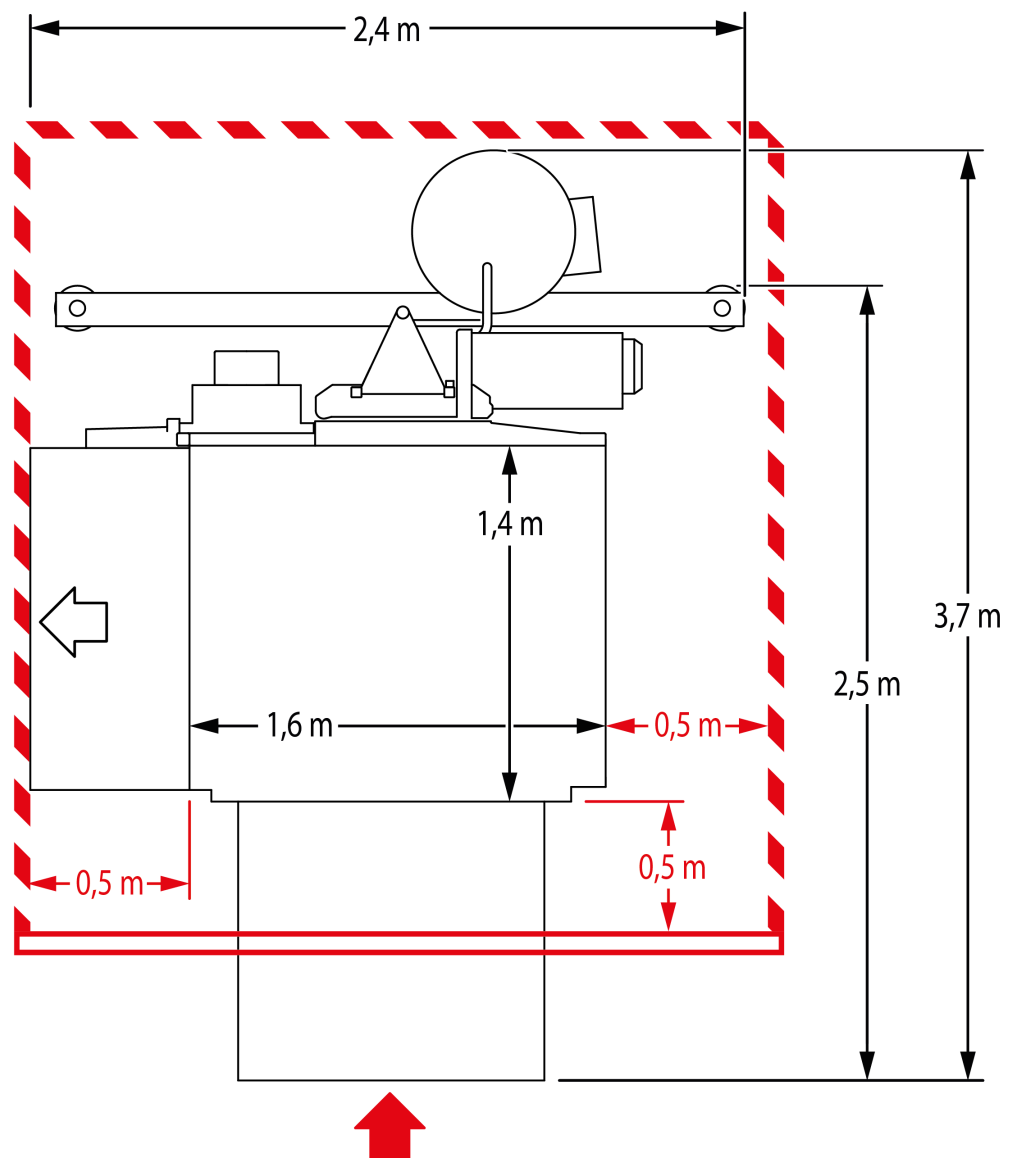

Fig. 7: Required space platform B

Height 2.3 m (2.5 m with roof)

Weights

Base unit with platform 825 kg

Roof 24 kg





Underrun protection 25 kg

3.8.3 Platform C



Fig. 8: Platform C

Load capacity

Construction hoist	max. 800 kg
Transport platform	max. 500 kg / 5 persons
	400 kg + 1 
	300 kg + 2 
	200 kg + 3 
	100 kg + 4 
	----- kg + 5 
Assembly up to the second mast tie	250 kg
Assembly from the second mast tie	500 kg

Dimensions/required space

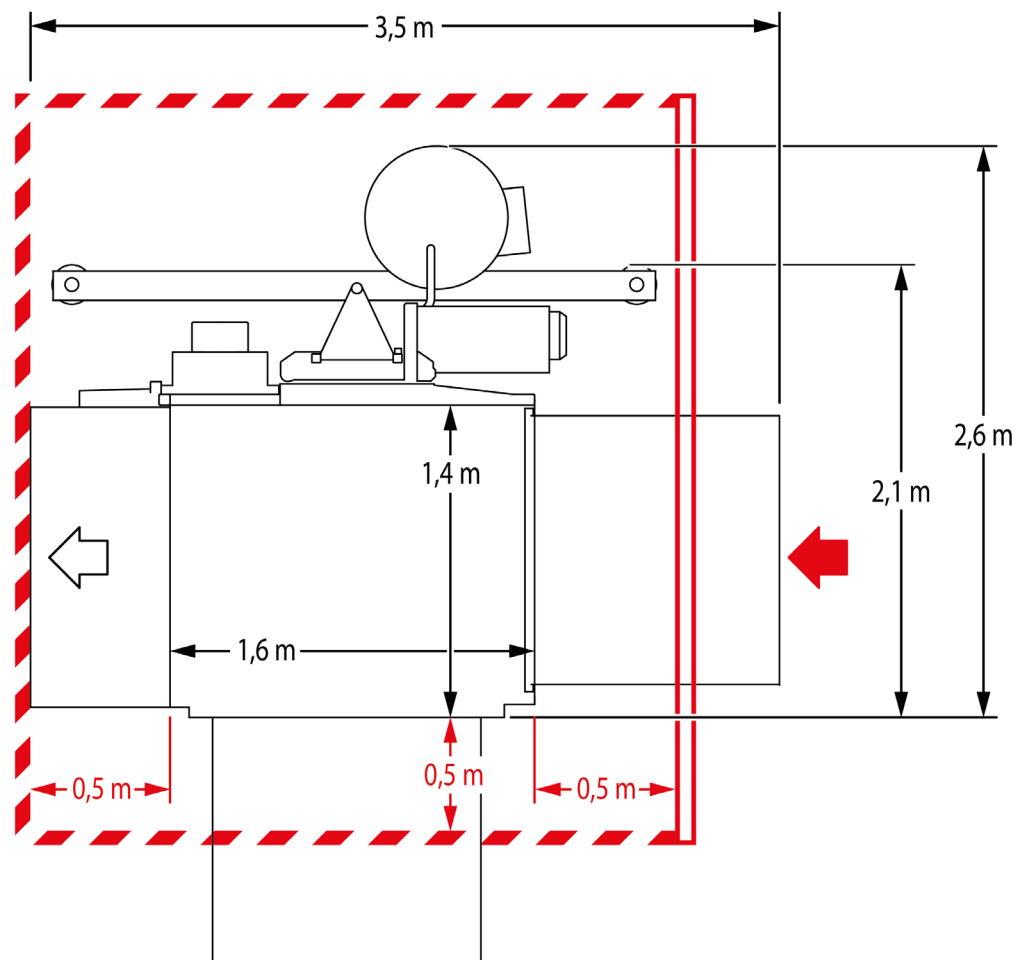

Fig. 9: Required space platform C loading B-side

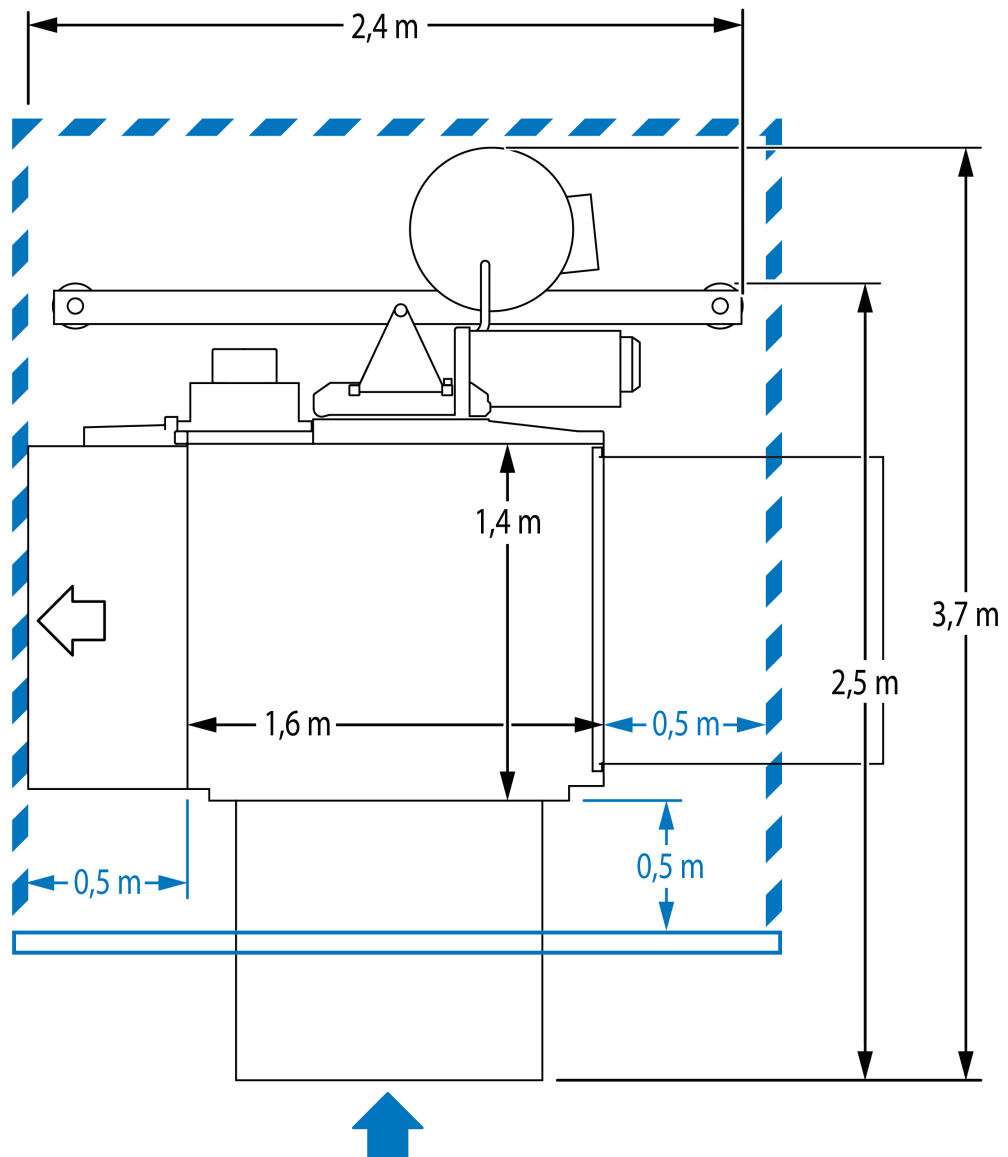

Fig. 10: Required space platform C loading C-side





Height	2.45 m (2.5 m with roof)
Weights	
Base unit with platform	884 kg
Roof	24 kg
Underrun protection	25 kg

3.8.4 Platform SL



Fig. 11: Platform SL

Load capacity

Construction hoist	max. 850 kg
With attached roof, underrun protection and assembly plank	max. 670 kg
Transport platform	max. 500 kg / 5 persons
	400 kg + 1 
	300 kg + 2 
	200 kg + 3 
	100 kg + 4 
	----- kg + 5 
Assembly up to the second mast tie	250 kg
Assembly from the second mast tie	500 kg

Dimensions/required space

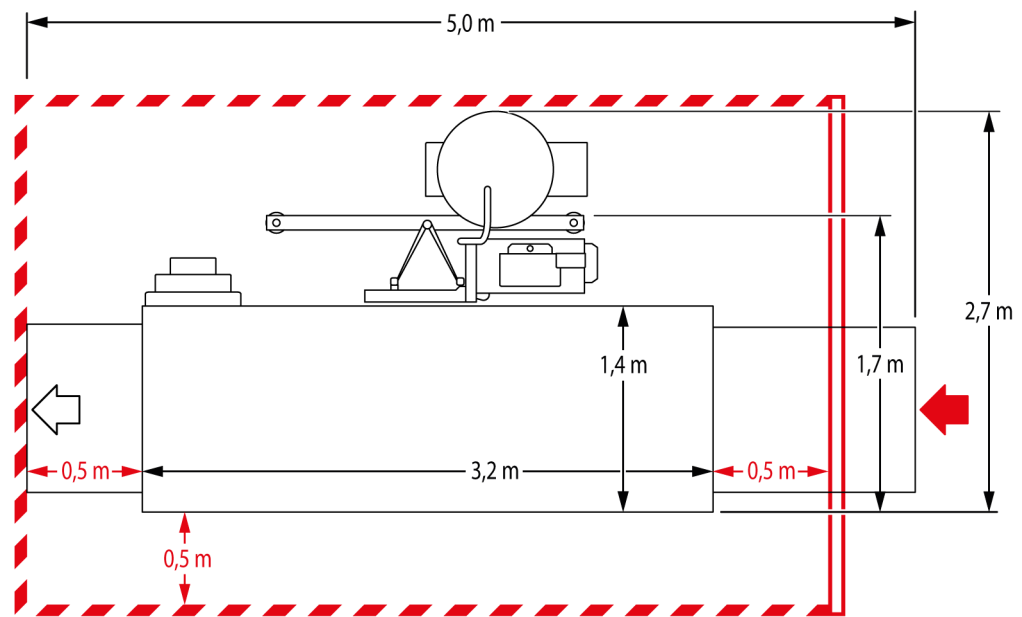

Fig. 12: Required space platform SL

Height 2.45 m (2.5 m with roof)

Weights

Base unit with platform 1000 kg

Underrun protection 35 kg

The roof is included in the weight figure for the base unit.

3.8.5 Platform 500 ZP/1000 Z 2

Special preconditions for the 500 ZP/1000 Z 2

The **GEDA 500 ZP/1000 Z 2**, serial no. 62750, has a maximum load capacity of 1000 kg when used as a material hoist and under special preconditions.

These preconditions are:

- Only UNI-X-Mast sections are used.
- The load must be positioned as close to the mast as possible. The centre of gravity of the load can be in the centre of the platform at a maximum.
- The installed height is limited to max. 100 m.
- The maximum mast protrusion (W) is limited to 2 m.

⚠ DANGER	
	<p>Danger to life Limited overrun at the last mast bracket. Dimension W = max. 2 m Mast bracket to top track rollers approx. 0.5 m below the mast end.</p>





- The duty cycle (DC) of the drive is 20 %.

The **GEDA 500 ZP/1000 Z 2** is available as "platform A", "platform B" and "platform C".



The load capacity in each case applies only without special attachments. Installation of optional equipment (e.g. roof, underrun protection, assembly plank) increases the dead weight. The load capacity decreases accordingly.

Load capacity

Construction hoist platform A	max. 1000 kg
Construction hoist platform B	max. 1000 kg
Construction hoist platform B	max. 950 kg
Transport platform	max. 500 kg / 5 persons
	400 kg + 1 
	300 kg + 2 
	200 kg + 3 
	100 kg + 4 
	----- kg + 5 
Assembly up to the second mast tie	250 kg
Assembly from the second mast tie	500 kg

Dimensions/required space



For dimensions and footprint see chapters "Platform A", "Platform B" and "Platform C".

Weights

Base unit with platform A or B	825 kg
Base unit with platform C	884 kg
Roof	24 kg
Underrun protection	25 kg

4 Operation

The 500 Z/ZP 2 may only be operated by a qualified person appointed by the operating company. This person must be familiar with the operating manual, have sufficient experience and be informed about the risks involved in handling lifting gear.

See chapter 1.8 Intended use

4.1 Safety during operation

- Chapter 2 General safety information also has to be observed.
- Load the platform as centrally as possible, observe the load capacity of the machine.
 - The platform must always be loaded in such a manner that the loading and unloading access points and the control point remain accessible.
 - Position the load carefully on the platform; material that might tend to slip or is higher than the platform, or which could fall over, must be secured (consider the possibility of sudden winds).
 - Do not transport bulky parts that project over the side of the platform.
- Do not stand or work under the platform!
- Do not place objects underneath the platform.
 - Store material at a safe distance of min. 50 cm (20") from moving parts of the machine.
- The landing level safety gates may only be opened once the unloading ramp has been completely opened.
- If the loaded platform stops during operation due to a malfunction, it is the responsibility of the operator to recover the load. - Never leave a loaded platform unattended!
- Operation of the transport platform must cease under the following conditions:
 - at temperatures below -20°C and above +40 °C.
 - in case of damage or other malfunctions.
 - A recurring inspection/intermediate inspection has been missed (refer to the maintenance manual).

DANGER



Danger to life

- Do not use in case of fire!

4.1.1 Special safety instructions for operation as a material hoist

- Operation of the material hoist must take place outside the hazard area.
- The operator must always be able to observe the platform.
- Transporting persons is prohibited!
- Switch to "transport platform" mode to carry out assembly and maintenance tasks.

4.1.2 Special safety instructions for operation as a transport platform

- Operation of the transport platform must be carried out exclusively from the platform control.
- Special care must be taken near ground level.
- A max. of 5 passengers (including the platform operator) may be transported, whereby the corresponding proportion of transported materials must be reduced.
- Comply with the instructions of the platform operator.
- Do not reach or lean out over the sides of the platform.
- Do not step over material that is being transported.

Instructions for operation as per EN 16719

⚠ WARNING	
	<p>Risk of injury Injuries from falling parts or inexpert securing of the hazard area.</p> <ul style="list-style-type: none"> ➤ Passenger transport only with <ul style="list-style-type: none"> - the roof installed - cordon and underrun protection or - base enclosure 1.10 m with barrier and underrun protection or - 2.00 m base enclosure with sliding door - closed landing level safety gate

4.2 Commissioning

- 1 Main switch
- 2 Control light, ready for operation
- 3 Socket [blue] for ground control/manual control
- 4 Socket [red] for electric module on the landing level doors (or dummy plug during assembly)

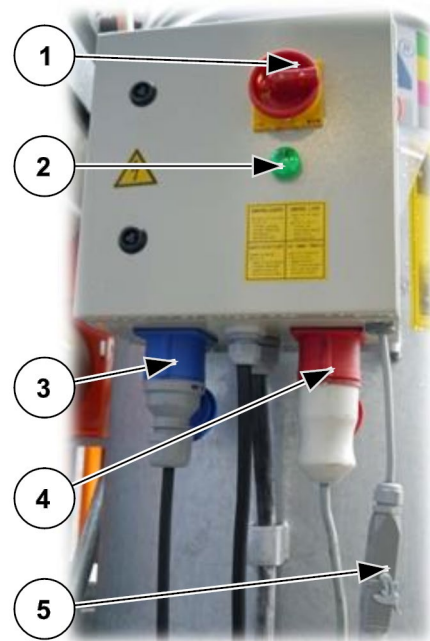

Fig. 13: Ground station switch box

Only with 2.00 m base enclosure with sliding door

- 5 Socket [grey] for 2 m base enclosure with sliding door (or dummy plug without this base enclosure)



The connected control of the 2.00 m base enclosure automatically switches the safety functions (stop and warning signal) for the lower safety area.

- Turn the main switch to the "I" position [ON] .
 - ✓ The green control light (2) lights up for confirmation.

Trolley switch box

- Set the key switch (10) to position 0 and remove the key,

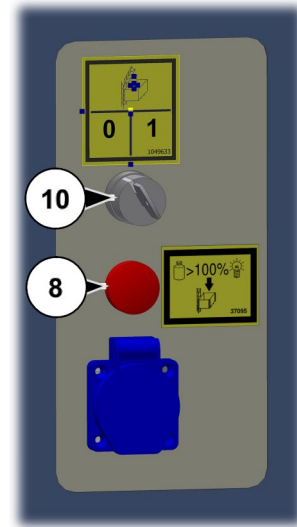

Fig. 14: Selector switch for operating mode, ready for operation



The key has to be removed to prevent incorrect operation during operation.

4.2.1 Safety check before starting work

Perform a test run with an **empty** platform and check that the entire travel path of the platform is clear.

The platform must immediately stop when

- an **EMERGENCY STOP** button is pressed.
- the **UP** limit switch is triggered.
- the **DOWN** limit switch is triggered.
- the **EMERGENCY** limit switch is triggered.
- the trolley has reached the end of the mast
- the OFF button on the electric module of the landing level safety gate (if there is one) is pressed.

The platform must not start if

- it is overloaded (red control light illuminates).
- the barrier with the unloading flap is open.
- the loading door/ramp is open.
- the assembly guard is lowered.
- the safety gear has been triggered.
- the landing level safety gate is open (only when using the electric module).
- an assembly plank is open.

Alarm signal function test

- When descending, the platform must stop at the lower safety area. Then a warning signal must sound for approx. 3 s. (During this time the control function is blocked.) Also, the warning signal must sound each time travel (**UP and DOWN**) below this safety area is initiated.

The platform must not continue to operate automatically when used as a material hoist, if

- the selector switch on the ground control is set to "I".
- the platform is located at ground proximity regardless of the selector switch position.



When operating the platform as a construction material hoist close to ground (in the lower safety area), it must not be possible to operate it from the landing level safety gate.

4.3 Operation/function

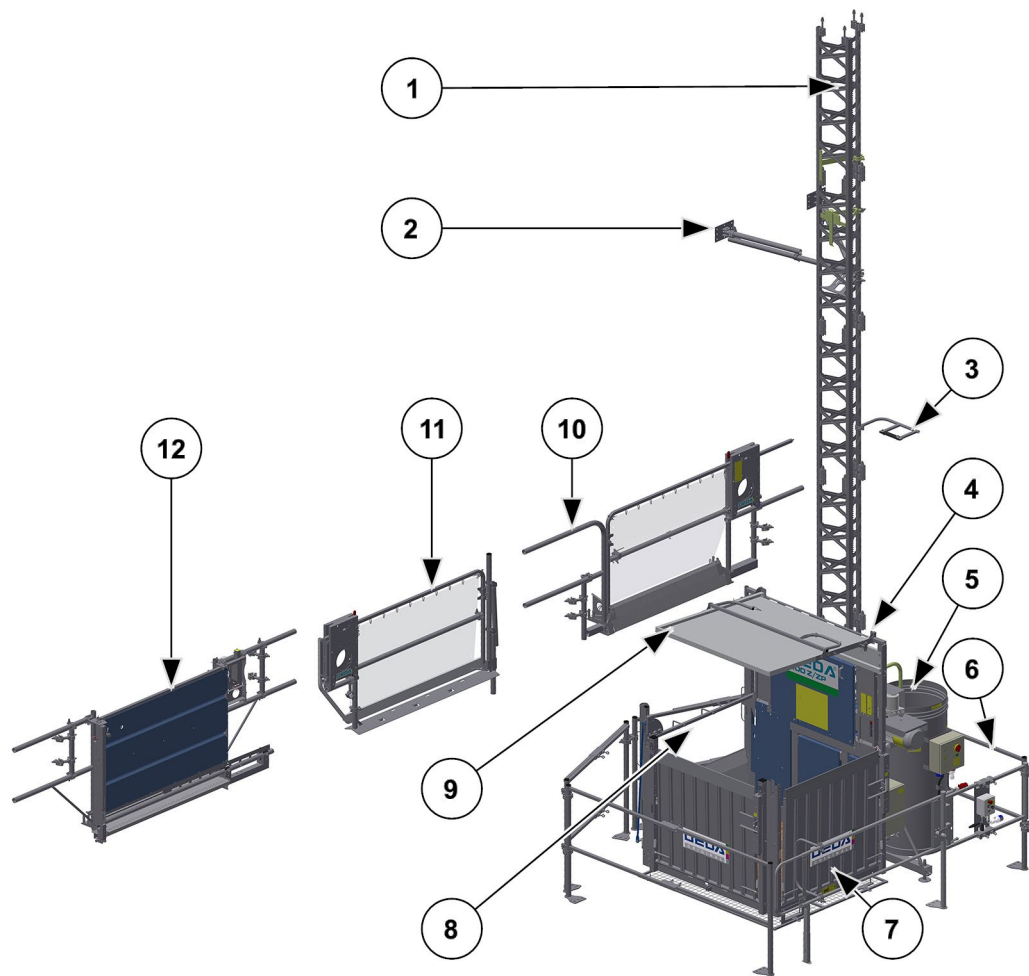



Fig. 15: Overview

- | | | | |
|---|-----------------------------|----|--|
| 1 | Mast section | 7 | Platform access, ground station (ramp/door) |
| 2 | Mast tie | 8 | Building platform access (barrier with loading ramp) |
| 3 | Cable guide | 9 | Roof |
| 4 | Base mast with foot section | 10 | "Comfort" landing level safety gate |
| 5 | Cable bin | 11 | "Standard" landing level safety gate |
| 6 | Base enclosure | 12 | "VARIO" landing level safety gate |

4.3.1 Securing the lowest stop position (ground station)

The lowest stop position must be secured and marked to prevent unauthorized access.

⚠ DANGER	
	<p>Danger to life from lowering platform</p> <ul style="list-style-type: none"> ➤ Never remain inside the cordoned area/base enclosure during operation. ➤ Whilst working inside the base enclosure, switch off the main switch and secure it against being switched on. Secure the platform, if necessary, or activate the setting on permanent machines.

Operating the transport platform as per EN 16719

- If the underrun protection is installed below the platform, a cordon is sufficient for securing the ground station
or
a base enclosure 1.10 m with barrier with limit switch monitoring
- Without underrun protection, a 1.10 m base enclosure with electromechanically locked barrier has to be installed
or
a 2.00 m base enclosure with barrier with sliding door



The transport platform must not be operated without a cordoned off zone or base enclosure.

⚠ WARNING	
	<p>Risk of injury</p> <ul style="list-style-type: none"> ➤ The distance of the cordon/base enclosure to moving hoist parts must be a minimum of 0.5 m and maximum of 2.0 m.

4.3.1.1 Cordon



The cordon may only be used in combination with the underrun protection installed!

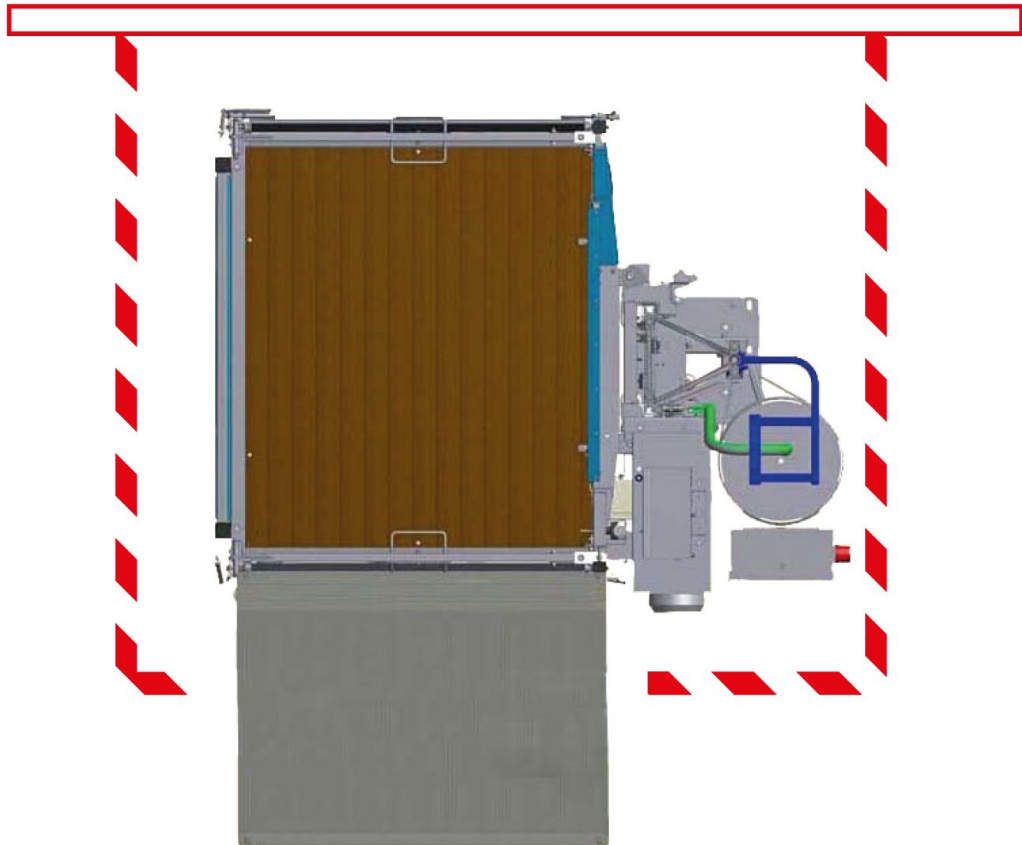

Fig. 16: Cordon

⚠ WARNING**Risk of injury from impaired view**

- The operator always has to check whether the travel path to the ground station is clear!

4.3.1.2 1.10 m base enclosure with barrier (option)



Fig. 17: 1.10 m base enclosure with barrier

Height = 1.10 m

Distance to moving hoist parts = min. 0.5 m

Opening

- Raise the barrier up.

Closing

- Lower the barrier until it rests on the enclosure post.



The platform can be operated only when the barrier of the base enclosure is closed.

The barrier can optionally be installed to open to the left or to the right.

Assembly of the 1.10 m base enclosure with barrier is described in detail in a separate assembly manual.

⚠ WARNING



Risk of injury from impaired view

- The operator always has to check whether the travel path to the ground station is clear!

4.3.1.3 Sliding door for 2.00 m base enclosure (option)

As an alternative to the 1.10 m base enclosure with barrier, the 2.00 m base enclosure with sliding door can be installed.

The sliding door for the base enclosure is installed on the access side and it must be extended on-site, e.g. with a fence around the base unit.



The sliding door for the base enclosure can only be opened when the platform is stationary at the ground station.



Fig. 18: Sliding door for ground base enclosure

After this 2 m high base enclosure is installed, the platform can be moved directly to the ground station without a delay limit switch (at the lower safety area).



The platform can be moved only with the sliding door closed.

The sliding door for the base enclosure can be optionally installed to open to the left or right.

Comprehensive assembly instructions are provided in the assembly manual for the sliding door (AM018).

Opening

- Press and hold the button (1/2) until the door is pushed out of the lock.

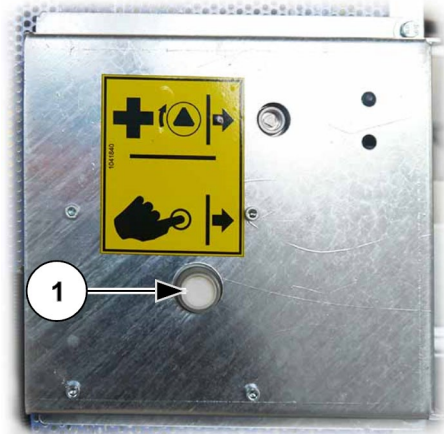

Fig. 19: Unlocking the sliding door lock

- Use the door handle (3) or safety bar (4) to push open the sliding door.

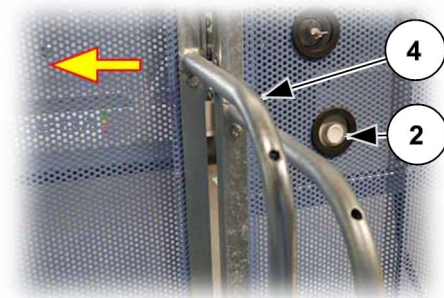

Fig. 20: Opening the sliding door

Closing

- Use the door handle (3) or safety bar (4) to close the sliding door until the door engages in the door lock.

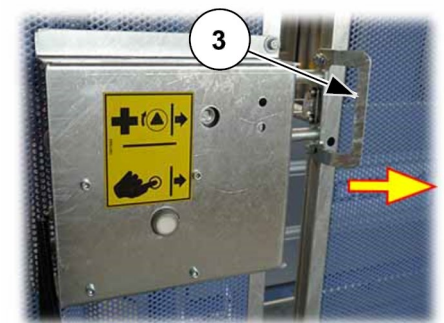

Fig. 21: Closing the sliding door

The loading ramp on the platform can only be opened when the sliding door is open.



Fig. 22: Sliding door for base enclosure open



Operation with sliding door and high base enclosure
 - DOWN travel without stopping at the lower safety area
 - Control from the landing level to the ground station

Emergency release

Door lock from outside

- Insert the triangular key (2) into the triangular door lock bolt (1) and turn clockwise until the sliding door can be opened.

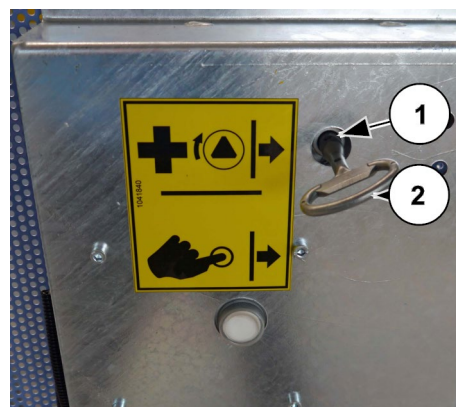

Fig. 23: Emergency release for sliding door from outside



After emergency release, the triangular key (1) must be turned back anticlockwise!

Door lock from the inside

- In order to unlock the door lock, rotate the activating lever (3) in the opposite direction.

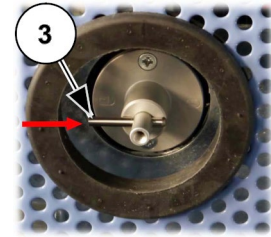

Fig. 24: Door lock unlocked

- After emergency release, the activating lever (3) must be reset!

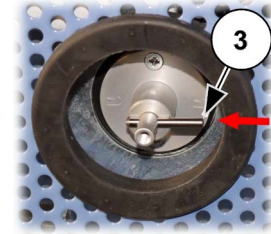

Fig. 25: Door lock locked

4.3.2 Platform access at the ground station



This access point to the platform can only be opened if the platform is stopped by the down limit switch at the ground station.

4.3.2.1 Loading door / Ramp

Opening

- Push/pull the loading door/ramp (1) inwards with one hand.
- Lift/lower the interlock hook (2).
- Open the loading door or carefully lower the ramp.



Fig. 26: Locking the loading door/ramp

Closing

- Close the loading door/ramp (1) and push/pull inwards until the interlock hook (2) engages.

Front platform access points

(For platforms A, B and C only)

The front ramp is standard for platforms B and C.

An additional ramp (1) or loading door (4) can be installed at the front of the platform.

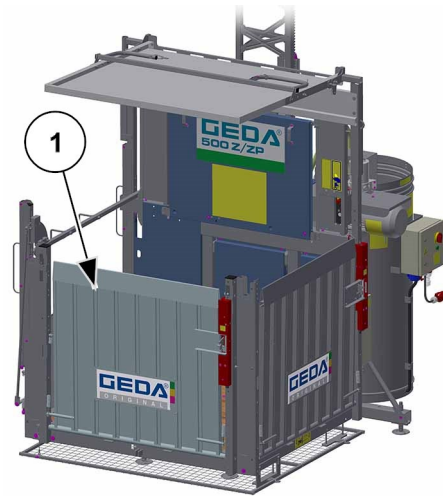

Fig. 27: Platform with front ramp

Loading door

Instead of the ramp, the loading door (double door) (4) can be installed on the front or side of the platform.



Fig. 28: Platform with loading door

Emergency release

In the event of a power failure, the access to the platform can be manually unlocked at the ground station.

Opening the ramp/door

- Insert the triangular key (3) into the lock and turn to the right.
- Lift/lower the interlock hook (2) and carefully open the ramp (1)/loading door (4).
- Remove the key (3).

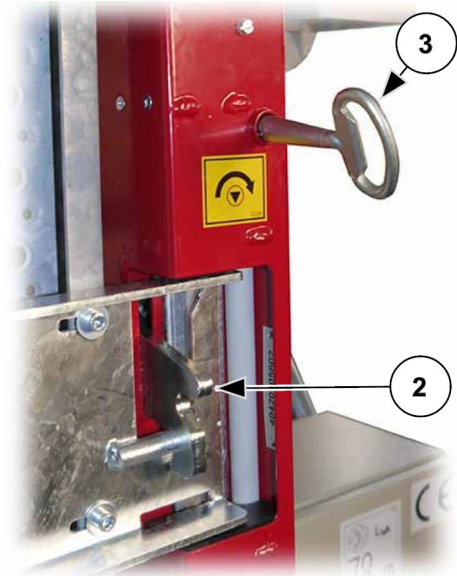

Fig. 29: Emergency release for ramp/loading door

4.3.3 Platform access landing level

Access to the landing level/scaffolding is secured with a barrier. The loading ramp automatically folds down when the barrier is opened.

The open loading ramp unlocks the landing level safety gate.

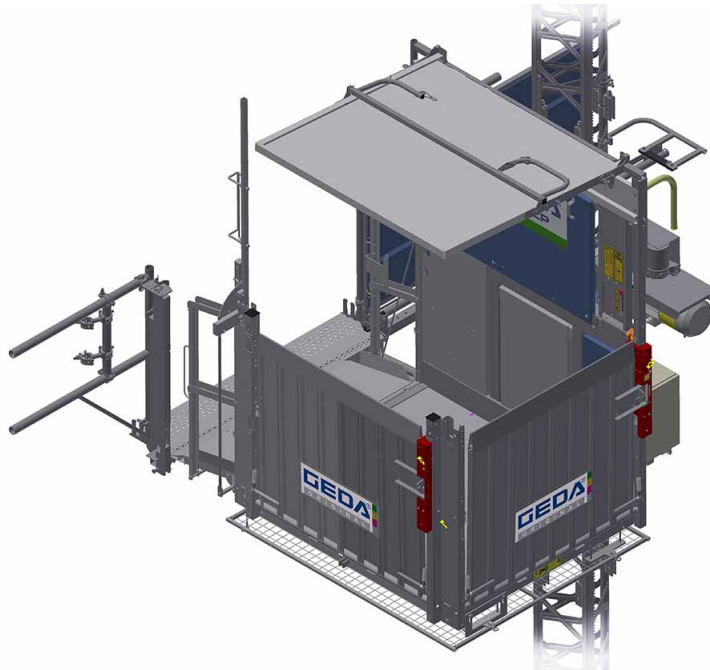

Fig. 30: Platform access landing level

4.3.3.1 Barrier with mechanical lock

The barrier must only be opened when the platform is located at the landing level in front of a landing level safety gate.

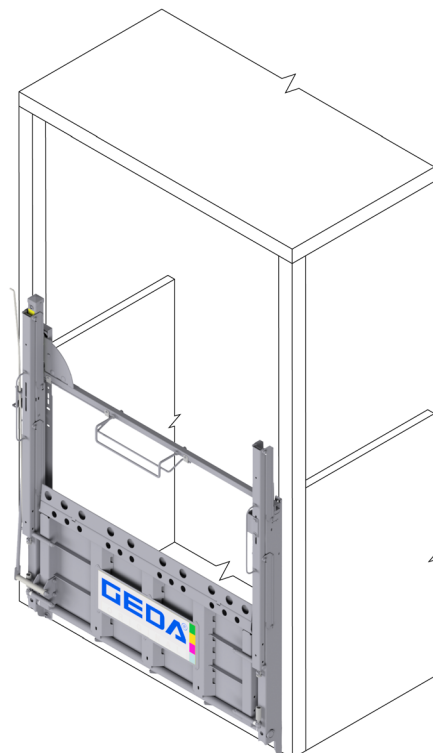

Fig. 31: Barrier with mechanical lock



Two separate actions are required for opening the barrier.

Opening

- Press the bar of the barrier interlock (9) towards the handle of the barrier (1).
- Swivel up the barrier (1).

The loading ramp opens.

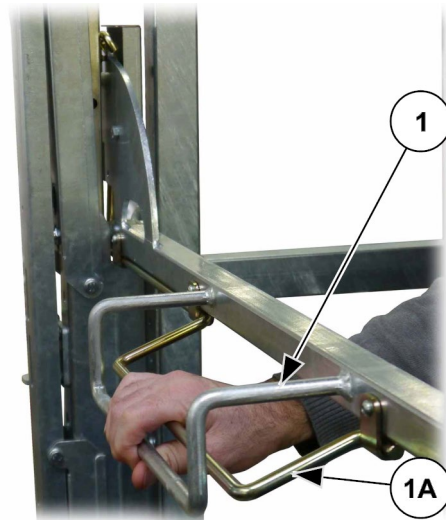

Fig. 32: Opening barrier with mechanical lock

Closing

- Lower the barrier (1) until it engages in the lock.

The loading ramp closes automatically.

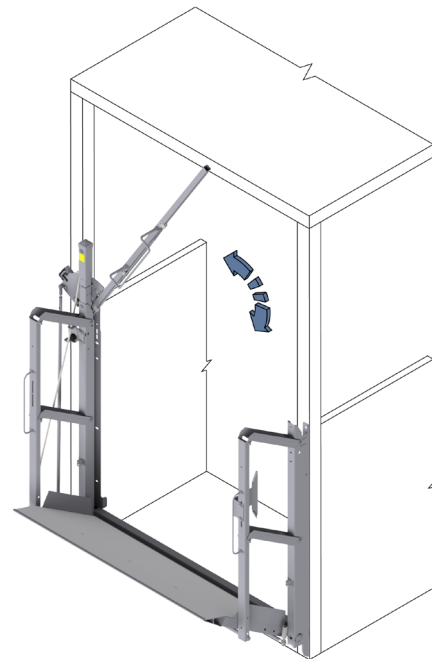

Fig. 33: Closing barrier with mechanical lock

4.3.3.2 Barrier with electromagnetic lock

Option as replacement for the barrier with mechanical lock.

The barrier is always locked and is automatically unlocked at the landing level (from the landing level stop bar). The barrier with loading ramp can only be opened at the landing level in front of a landing level safety gate.



Fig. 34: Barrier with electromagnetic lock

Opening

- Raise the barrier (1).

The loading ramp opens automatically and unlocks the landing level safety gate.



Fig. 35: Opening/closing the barrier with electromechanical lock

Closing

- Carefully lower the barrier (1) until it engages in the lock.

The loading ramp closes automatically.



The barrier must be open by approx. 45° in order for the control to switch to external control.

Emergency release

- Insert the triangular key (2) into the lock.
- Turn the key (2) counter-clockwise to the left while lifting the barrier.
- Release and remove the key.
- Open the platform access.



Fig. 36: Emergency release of the barrier with electromechanical lock

4.3.4 Securing loading and unloading points

To prevent persons falling, fall protection must be installed at all loading and unloading points where there is a risk of falling from a height of more than 2 m.

Only landing level safety gates for the checked and approved GEDA hoists may be used which ensure safe transition to the building in conjunction with the platforms.

GEDA landing level safety gates that have been inspected and accepted with the GEDA transport platforms comply with these requirements.

Safe working

Open landing level safety gate

Falling from a landing level

- If a closed landing level safety gate is required, a conversion kit for the "Standard", "Standard Basic" and "Comfort" landing level safety gates has to be retrofitted!

4.3.4.1 "Standard/Standard Basic" landing level safety gate



These landing level safety gates can only be opened once the loading ramp has been completely opened.



Fig. 37: Standard landing level safety gate no. 01217/01268

"Standard" landing level safety gate closed (tarpaulin)

(Option as per EN 16719)

The retrofit kit article no. 1130276 can be used to retrofit the "Standard" landing level safety gate with a tarpaulin.



These landing level safety gates can only be opened once the loading ramp has been completely opened.

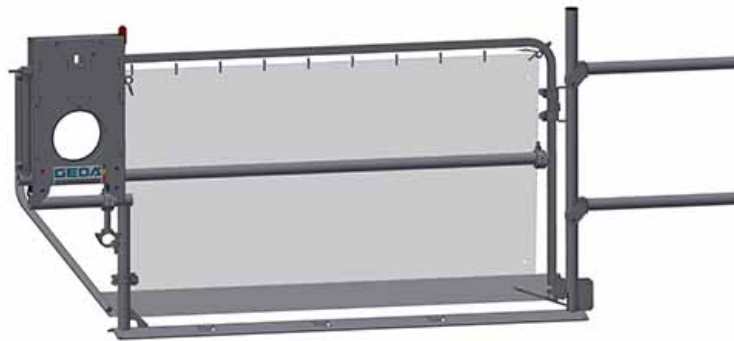

Fig. 38: "Standard" landing level safety gate closed (tarpaulin)

Opening

- Press the lever (1A) in the direction of the arrow and push open the sliding door (1).

Closing

- Close the sliding door (1) until the lever (1A) engages downwards.

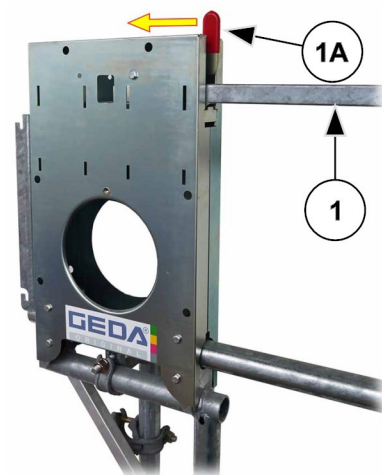

Fig. 39: Opening/closing the "Standard" landing level safety gate

4.3.4.2 "Comfort" landing level safety gate



It is only possible to open this landing level safety gate when the unfolded unloading ramp is in contact with the sill of the landing level safety gate.



Fig. 40: "Comfort" landing level safety gate no. 01212

"Comfort" landing level safety gate closed (tarpaulin)

(Option as per EN 16719)

The retrofit kit article no. 1130296 can be used to retrofit the "Comfort" landing level safety gate with a tarpaulin.

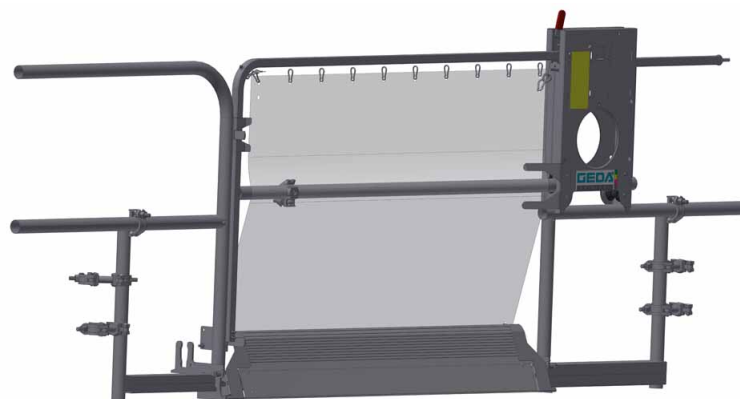

Fig. 41: "Comfort" landing level safety gate closed (tarpaulin)

"Comfort" landing level safety gate closed (perforated plate)
(Option as per EN 16719)

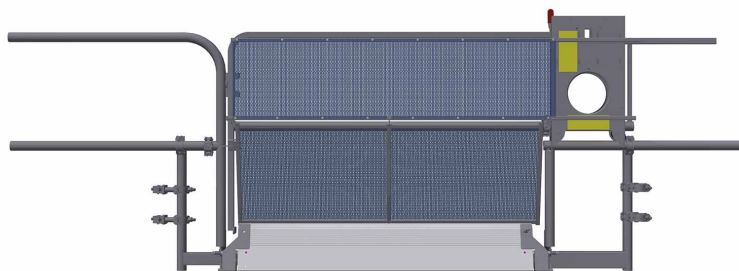

Fig. 42: "Comfort" landing level safety gate closed (perforated plate)

Opening

- Press the lever (2A) in the direction of the arrow and push open the sliding door (2).

Closing

- Close the sliding door(2) until the lever(2A) engages downwards.

Image shows optional accessories

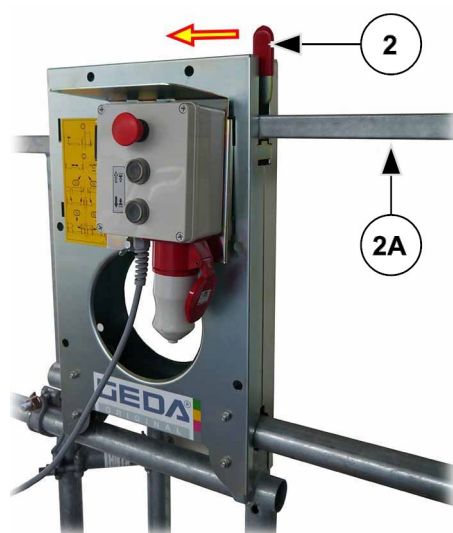

Fig. 43: Opening/closing the "Comfort" landing level safety gate

4.3.4.3 "VARIO" landing level safety gate (Option as per EN 16719)



This landing level safety gate can only be opened if the ramp interlock of the platform loading ramp or the car was actuated.



Fig. 44: "VARIO" landing level safety gate no. 68000

Opening

- Lift the ball handle (3A) for unlocking the door leaf and slide open the door leaf (3).

Closing

- Close the door leaf (3) until the ball handle (3A) engages downwards.

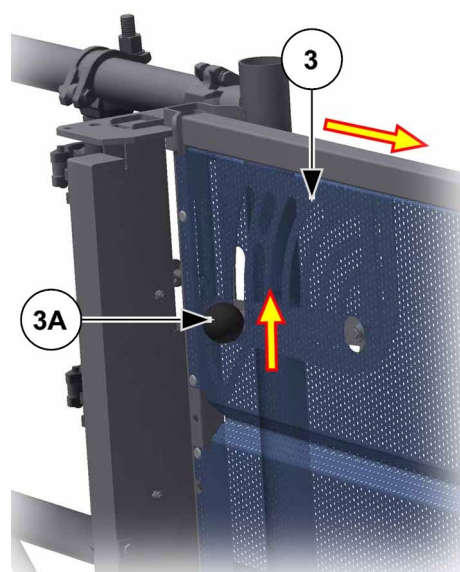

Fig. 45: Opening/closing the "VARIO" landing level safety gate

Emergency release

- Insert the triangular key (4) into the lock.
- Turn the key (4) to the right.
- Carefully open the door leaf (3).
- Remove the key (4).

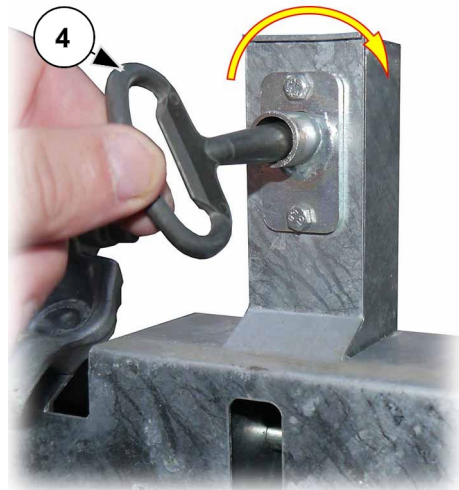

Fig. 46: Emergency unlocking of the landing level door

4.3.5 Controls

4.3.5.1 Functional description

The "**transport platform**" operating mode (platform control) has to be activated.

The platform operator has to activate the platform control at the key switch on the platform control each time after entering the platform. For confirmation, a green control light above the platform control also lights up.

The "**Construction hoist**" operating mode (external control) is automatically activated.

When leaving the platform, the "Construction hoist" (external control) operating mode is activated automatically. For confirmation, a green control light above the platform control lights up.

- The machine is fitted with an overload detection device. If the load capacity is exceeded, this switches off travel movement in both directions and the red control light on the platform control illuminates.
- The lifting speed of the platform is approx. 12 m/min from the platform control or approx. 24 m/min from the external controls.
- The lower safety area is specially secured.
 - The lifting speed of the platform is only about 12 m/min.
 - **DOWN** travel is only possible using dead man's control.
 - When the platform is descending, it stops at the lower safety area and, before starting in this area (**UP and DOWN**) a signal is emitted for approx. 3 s.
 - Within this zone, **the hoist cannot be operated from the landing level control.**



When using the 2.00 m base enclosure with sliding door, the lower safety area is omitted. The platform can then be moved down to the ground station using all controls.

- The platform openings (barrier, door/ramp, assembly guard, assembly plank) are electrically monitored and interrupt the safety circuit when opened so that the platform immediately stops or does not move off.
 - The access at the ground station can only be opened when the platform is actually at the ground station.
- The downward travel path of the platform is limited by a **DOWN** limit switch and the upward travel path is limited by an **UP** limit switch. If one of these limit switches is overrun due to a fault, the **EMERGENCY LIMIT** switch interrupts the **EMERGENCY STOP** safety circuit.
Further travel from the landing level limit switch is not possible in either direction.
- Installation of the construction hoist includes safety devices for the loading and unloading points (refer to the assembly manual).

Use as a material hoist

The key switch on the platform control has to be set to "0". Key removed.

The "Construction hoist" (external control) operating mode is automatically activated when leaving the platform.

A green control light ("Construction hoist" operating mode) above the platform control illuminates to confirm that this mode has been activated.

Operation is carried out using the ground control (manual control) outside the danger zone - or from the electric modules of the landing level control when outside of the lower safety area.

- When descending, the platform stops at the lower safety area. After the platform operator has ensured that the travel path is clear, they press and hold the **DOWN** button, then a signal is emitted. After approx. 3 seconds, the platform moves and stops at the limit switch.
- Automatic operation is possible above the lower safety area-

Use as a transport platform/climbing platform

For operation as a transport platform used to transport passengers as per EN 16719, the following has to be installed:

- a roof
- on the building – a platform access with barrier which can be operated with two separate actions
- an underrun protection and barrier **or**
- a base enclosure

The platform is intended for temporary use on construction sites for transporting persons and materials. It may only be used by trained personnel (platform operator) who receive the key to activate the platform control.

- To activate the platform control, insert the key into the key switch (5) and briefly switch/turn.
 - ✓ A green control light ("**Construction hoist**" operating mode) above the platform control lights up to confirm that this mode has been activated.
- The maximum number of persons on the platform is limited to 5 (incl. platform operator).
- Operation is only possible from the platform control in dead man's control. Other control locations are therefore disabled.
 - When descending, the platform stops at the lower safety area. After the platform operator has made sure that the travel path downwards is clear, they again press and hold the **DOWN** button, then a signal is emitted. After approx. 3 seconds, the platform moves and stops at the **DOWN** limit switch.
- It is possible to stop at any position (e.g. to carry out work from the platform or to unload bulky components over the enclosure).

4.3.5.2 Use as a construction hoist (external control)

[Ground control and electric modules at the landing levels]



The loading door/ramp, barrier with unloading ramp and assembly plank must be closed and engaged. The assembly guard must be properly attached at the top.

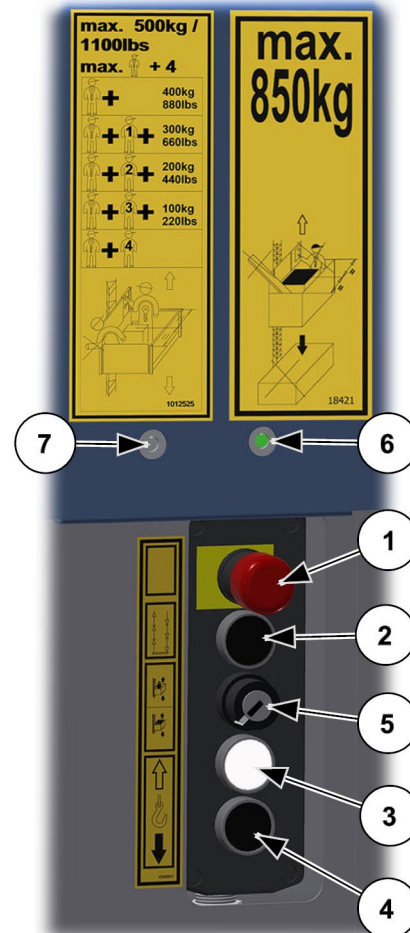

- 1 **Emergency stop** button
- 5 Key switch **operating mode**
- 6 **LED** display (external control active)

- The key switch (5) is not actuated.
 - ✓ The LED display (6) of the selected operating mode lights up.

Fig. 47: Actuating the external control



In this position, the key can be removed.

The ground control and the electric modules for the landing level safety gates are active.

Transporting of persons is prohibited with external control!

The machine can now be used as a material hoist.

Ground controls

The platform can be summoned to the ground station from higher stop positions or moved up to a landing level using the ground control.

Selector switch (13) to "I" position (dead man's control/MANUAL)

Ground control/manual control

- 1 **EMERGENCY stop** button
- 3 **UP** button
- 4 **DOWN** button
- 13 **Selector switch** MANUAL (I) - AUTOMATIC

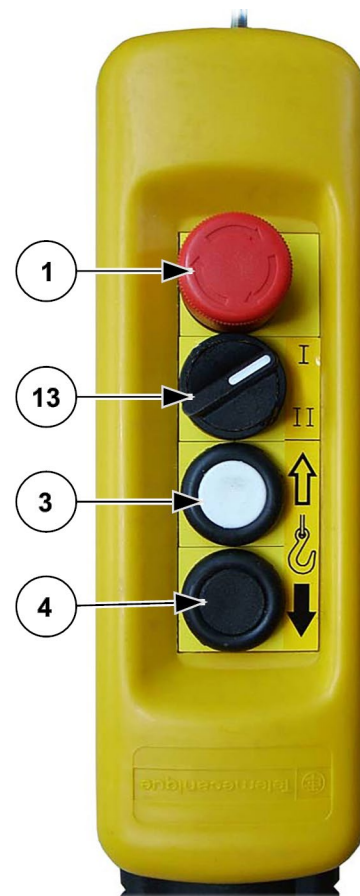

Fig. 48: Ground control/manual control (position I)

Ground control for base enclosure

- 1 **EMERGENCY stop** button
- 3 **UP** button
- 4 **DOWN** button
- 13 **Selector switch** MANUAL - AUTOMATIC

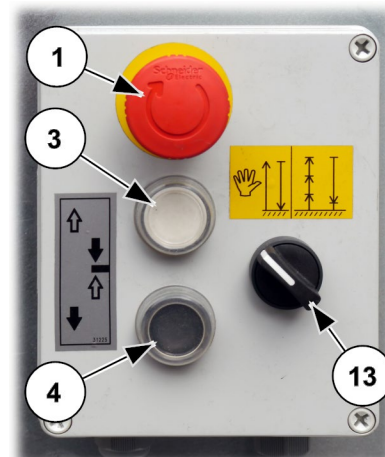

Fig. 49: Ground control for enclosure (MANUAL)

Travelling UP

- Press and hold the UP button (3).

The platform only moves while the UP button (3) is pressed. The platform overruns the LANDING LEVEL stop rail and is stopped by the UP limit switch.

Travelling DOWN

- Press and hold the DOWN button (4).

The platform only moves while the DOWN button (4) is pressed.

The platform stops before the lower safety area.

Exception: When using the 2.00 m base enclosure with sliding door, the platform does not stop before the lower safety area.

⚠ WARNING**Risk of injury from platform moving downwards**

- Ensure that the downward travel path is clear.
- Only then can downward travel be continued.

- Hold down the DOWN button (4) or press it again.

The system issues an alarm signal and after about 3 s, the platform will start moving and stop at the DOWN limit switch.

Selector switch (13) to "II" position (automatic travel)

Ground control/manual control

- 1 **EMERGENCY stop button**
- 3 **UP button**
- 4 **DOWN button**
- 13 **Selector switch MANUAL (I) - AUTOMATIC**

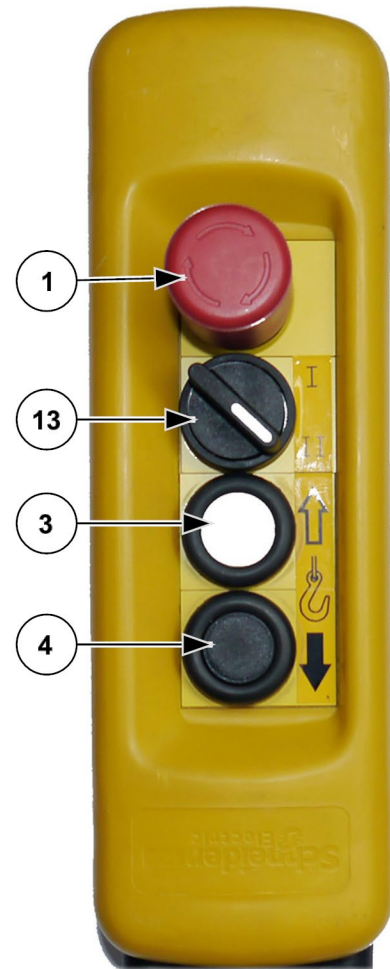

Fig. 50: Ground control/manual control (position II)

Ground control for base enclosure

- 1 **EMERGENCY stop button**
- 3 **UP button**
- 4 **DOWN button**
- 13 **Selector switch MANUAL - AUTOMATIC**

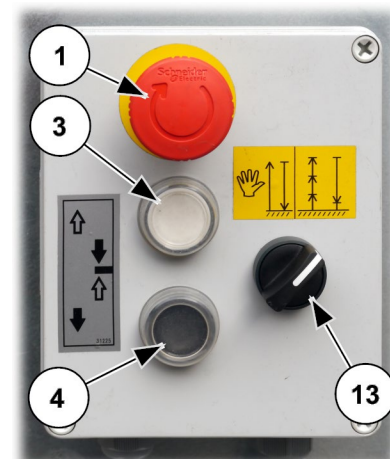

Fig. 51: Ground control for enclosure (AUTOMATIC)

Travelling UP

- Press and hold the UP button (3).

The platform only moves in the lower safety area while the UP button (3) is pressed.

- After exceeding this safety area, release the UP button (3).

The platform automatically travels onward to the next landing level and stops there.

- For continuous travel to the second landing level, press the UP button (3) until the landing level stop rail for the first landing level has been passed.

Travelling DOWN

- Press and release the DOWN button (4).

The platform travels downwards and stops before the lower safety area.

⚠ WARNING	
	<p>Risk of injury from platform moving downwards</p> <ul style="list-style-type: none"> ➤ Ensure that the downward travel path is clear. ➤ Only then can downward travel be continued.

- Hold down the DOWN button (4) or press it again.

The system issues an alarm signal and after about 3 s the platform will start moving and stop at the DOWN limit switch.

Electric module for landing level safety gate

The electric module must be installed on the landing level safety gates if local regulations specify electrical monitoring of the landing level sliding door or control of an upper stop position is required.



Control from the stop position is only possible in "Construction hoist" operating mode and only above the lower safety area.

- 3 **UP** button
- 4 **DOWN** button
- 14 **STOP** button (does not engage)

Additional equipment:
Extension cable 20 m

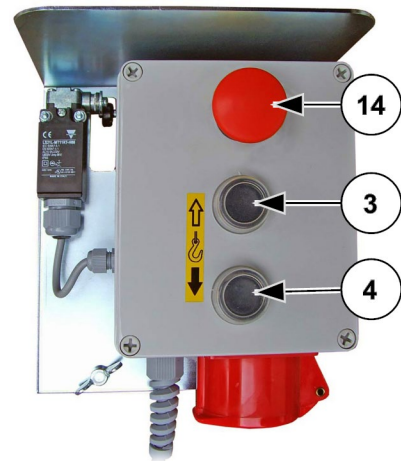

Fig. 52: Electric module for landing level safety gate



Operation depends on the position of the selector switch (13) and is identical to operation of the ground controls.

4.3.5.3 Operation as transport platform (platform control)

The transport platform can only be operated from the platform in dead man's control. The platform only operates while the operating button is pressed.



The platform control may only be used with adequate brightness levels (at least 50 lx)!

The platform may only be accessed and exited at stop positions above 2 m at the installed landing level safety gates.

The ramp, barrier with unloading ramp and assembly plank must be closed and engaged. The assembly guard must be properly attached at the top.



May only be operated by instructed personnel (platform operator).

- 1 **EMERGENCY STOP** button
- 2 **LANDING STOP** button
- 3 **UP** button
- 4 **DOWN** button
- 5 Key switch **operating mode**
- 6 LED display for "Construction hoist" operating mode is activated.
- 7 LED display for "Transport platform" operating mode is activated.

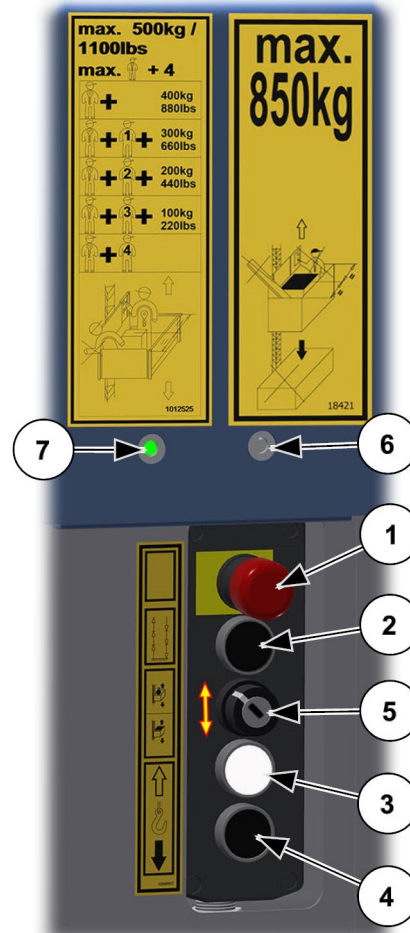

Fig. 53: Activating the platform control

- Insert the key in the key switch (5).
- Briefly rotate the key to the right to activate the platform control.
- Release the key.
 - ✓ The LED display (7) of the selected operating mode lights up.



Only the platform control is activated.

With the platform control activated, the machine has to be used as a transport platform.



In the lower safety area, the move command button (3/4) must be pressed for approx. 3 s until the platform moves. During this time, a warning signal is emitted.



Each time after entering the platform, the platform control has to be activated!

Travelling UP

- Press and hold the **UP** button (3).
 - ✓ The platform only moves while the **UP** button (3) is pressed.

Stop UP travel

- Release the **UP** button (3).
 - ✓ The platform reaches the UP END stop rail and automatically stops (the UP limit switch switches off).

Stop at landing level

If the platform is to be exited at a transfer point (landing level equipment) for loading and unloading, the platform must be stopped so that it is level with the landing-level safety door.



A LANDING LEVEL limit switch bar appropriate to the landing level safety gate has to be installed (refer to the Assembly Manual).



Always approach the LANDING LEVEL stop rail from below.

- Before reaching the landing level safety gate, press the **LANDING LEVEL STOP** button (2) in addition to the **UP** button (3).
 - ✓ The platform stops at the next landing level.
- First release the **UP** button (3) and then the **LANDING LEVEL STOP** button (2) [or both at the same time].

Travelling DOWN

- Press and hold the **DOWN** button (4).
 - ✓ The platform only moves while the DOWN button (4) is pressed.

Stop DOWN travel

- Release the **DOWN** button (4).
 - ✓ The platform descends and stops automatically above the lower safety area.

⚠ WARNING**Risk of injury from platform moving downwards**

- Ensure that the downward travel path is clear.
- Only then can downward travel be continued.

- Press and hold the **DOWN** button (4) again.
 - ✓ The system issues an alarm signal and after about 3 s the platform will start moving and stop at the DOWN limit switch.



When leaving the platform, activation of the platform control is switched off automatically!

4.3.6 Controls for special operation

4.3.6.1 Operation for assembly

For assembly, it is only possible to operate the hoist from the platform in dead man's control. The platform only operates while the operating button is pressed.

The ramp, barrier with unloading ramp and assembly plank must be closed and engaged. The assembly guard must be properly attached at the top.

- Turn the main switch (on the ground station switch box) to the "I" position (ON).

The key switch (10) must be turned to the right ("1" position).

The LED display (7) of the selected operating mode lights up.

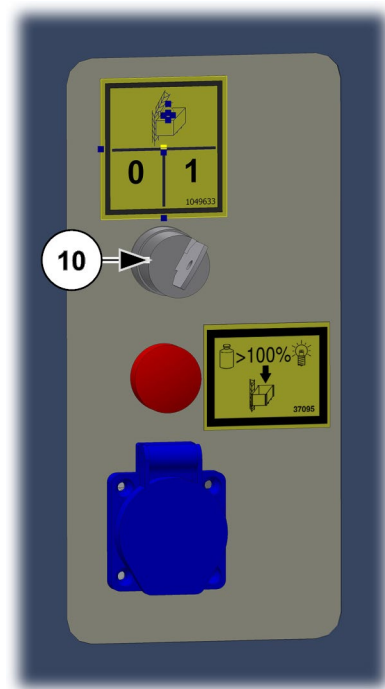
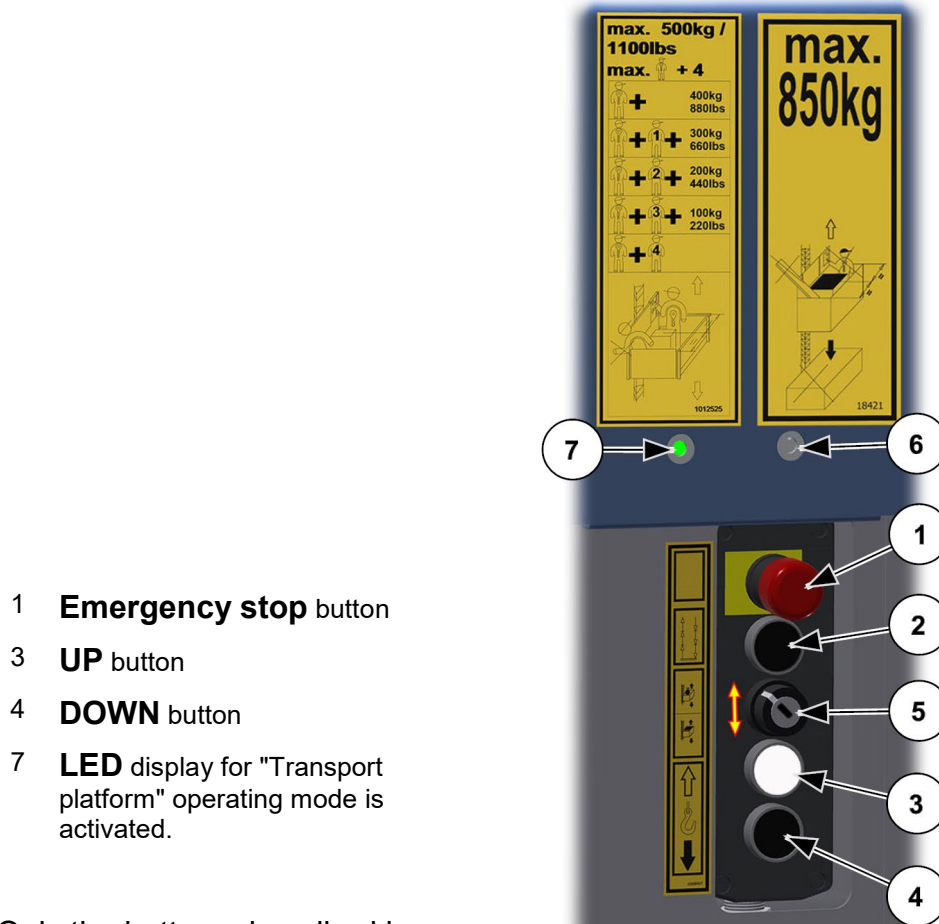

Fig. 54: Selector switch for operating mode, assembly



**In this position, the key cannot be removed.
Only the platform control is activated for assembly.**

⚠ WARNING	
	<p>Key for authorized persons</p> <p>The key (10) may only be used by assembly and maintenance personnel!</p>



Only the buttons described here are enabled for assembly!

Fig. 55: Platform control for assembly

Travelling UP

- Press and hold the **UP** button (3).
 - ✓ The platform only moves while the **UP** button (3) is pressed.

Stop UP travel

- Release the **UP** button (3).

Travelling DOWN

- Press and hold the **DOWN** button (4).
 - ✓ The platform only moves while the **DOWN** button (4) is pressed.

Stop DOWN travel

- Release the **DOWN** button (4).
 - ✓ The platform descends and stops automatically above the lower safety area.

⚠ WARNING



Risk of injury from platform moving downwards

- Ensure that the downward travel path is clear.
- Only then can downward travel be continued.

- Press the **DOWN** button (4) again and keep it pressed.

The system issues an alarm signal and after about 3 s the platform starts moving and stops at the **DOWN** limit switch.



Before operating the transport platform, the key switch (10) has to be set to position 0 and the key has to be removed!

4.3.6.2 Drop test control

The drop test control is inserted into the plug connection under the switch box of the platform.

- 1 **Emergency stop** button
- 2 Rotary knob for **brake release**
- 3 **UP** button

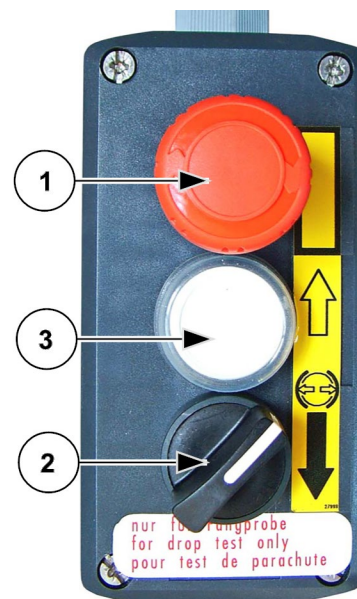

Fig. 56: Drop test control

4.3.7 Emergency shutdown

In situations that present a risk to operating personnel or the transport platform, the platform can be shut down by pressing an EMERGENCY STOP button.

An EMERGENCY STOP button is located at each control point.



Fig. 57: EMERGENCY STOP button



EMERGENCY STOP slam buttons are equipped with a latching mechanism and remain active until they are manually unlocked again (turn red button to the right and pull it out).



A stop button is located on the electric modules for the landing level safety gates and can be used to stop travel from each landing level. This stop button does not engage which means that further travel is immediately possible after the stop command.

4.4 Interrupting work – end of work

Switch off and secure the machine when interrupting work and at the end of work.

- Move the platform downwards until it stops at the DOWN limit switch.



If there is a risk of frost, move the platform up a little so that the DOWN limit switch is clear.

- Unload the platform.
- Remove the key from the key switch on the platform control.
- Turn off the main switch (position "0" [OFF]) and secure with a padlock.
- Disconnect the mains plug.



Fig. 58 Main switch secured

4.5 Equipment

4.5.1 Roofs

⚠ DANGER



Risk to life from falling parts

- For transporting passengers, a roof has to be installed as per EN 16719.

Function:

To protect people against falling parts.
To protect against direct sunlight/rain and snow.

Fold/swivel roof

Platforms "A", "B" and "C"

- 1 Roof



Fig. 59: Folding roof

For roof installation, refer to the Assembly Manual.



To mount the mast sections, the roof (1) to can be swivelled to the side (refer to the Assembly Manual).

⚠ WARNING



Risk of injury from falling parts

- Each time before folding back the roof, check if there are any components, stones or other construction material lying on the roof.
- Always clear the roof before folding it back!

Roof with assembly opening

Platform SL

The roof is firmly attached to the platform.

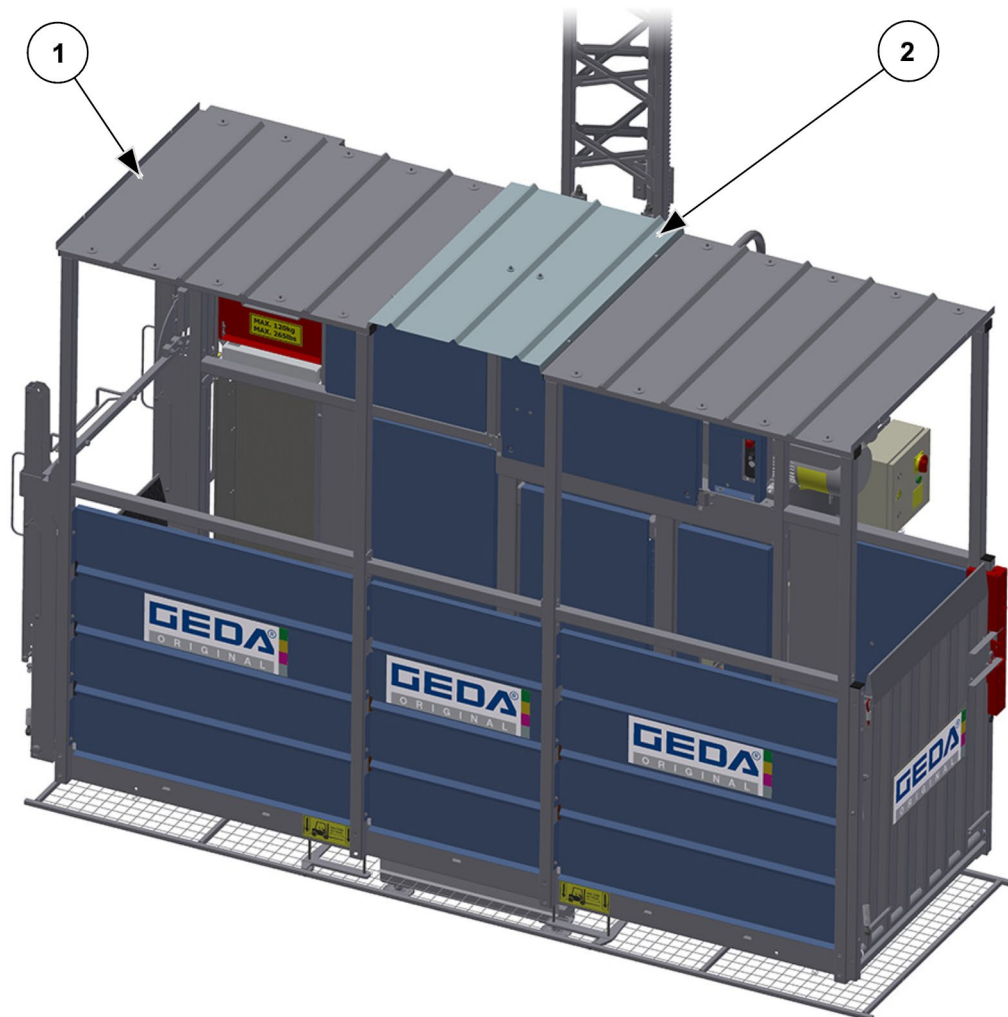

Fig. 60: Roof with assembly opening

- 1 Roof
- 2 Assembly opening

4.5.2 Assembly plank



The assembly plank may only be used during assembly and for maintenance.

The assembly plank is a thin, folding platform which helps with anchoring the mast sections from the platform (can also be used in front of a façade without frontal scaffolding).



Fig. 61: Assembly plank

4.5.3 Overrun and cable protection

The proximity switch (2) switches off before the drive pinion leaves the gear rack (e.g. during assembly) or before the traction on the trailing cable holder (1) is too great.

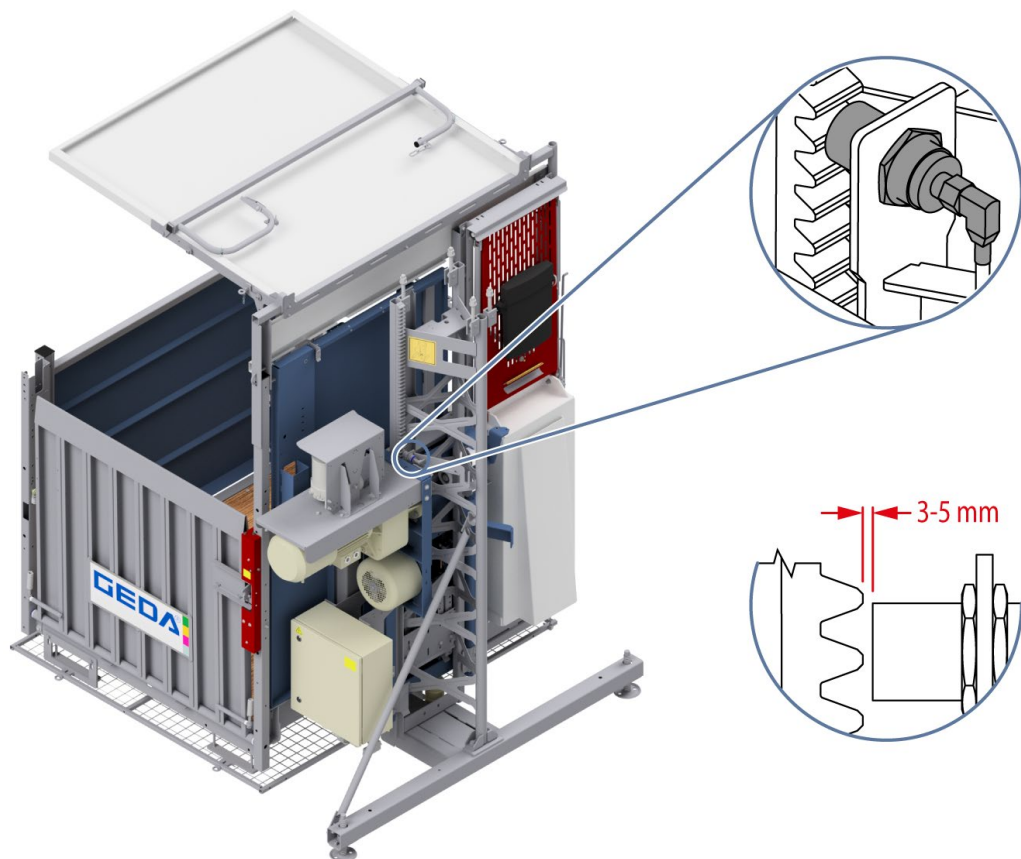

Fig. 62: Overrun and cable protection



The correct distance from proximity switch to gear rack is 3 - 5 mm.

4.5.4 Document and tool box

The document and tool box contains:

- 1 x triangular key for **EMERGENCY** release of the door lock and the barrier with electromagnetic interlock.



Fig. 63: Document box

The documents and tool box should contain:

- Operating Manual and Maintenance Manual for the machine
- Spare parts lists
- Circuit diagrams
- Operating instructions of the operating company
- Rescue plan of the operating company

4.5.5 Operating hours counter

An operating hours counter (1) is installed in the trolley switch box to record the operating hours (motor operating time).



Fig. 64: Operating hours counter



The switch box must be opened to read the counter. The switch box may only be opened by a qualified electrician!

4.6 Accessories

4.6.1 Underrun protection



For platforms with underrun protection, a cordon or a 1.10 m base enclosure with a barrier with limit switch monitoring is sufficient for securing the ground station!

Function:

Protects the transport platform against damage from hitting obstacles.

⚠ WARNING



Risk of injury from platform moving downwards

- Never remain inside the cordoned-off area during operation.
- Turn off the main switch and secure it from being switched on whilst working inside the cordoned-off area.

Protects persons who are underneath the platform without permission. They could be crushed by the platform during downward travel.

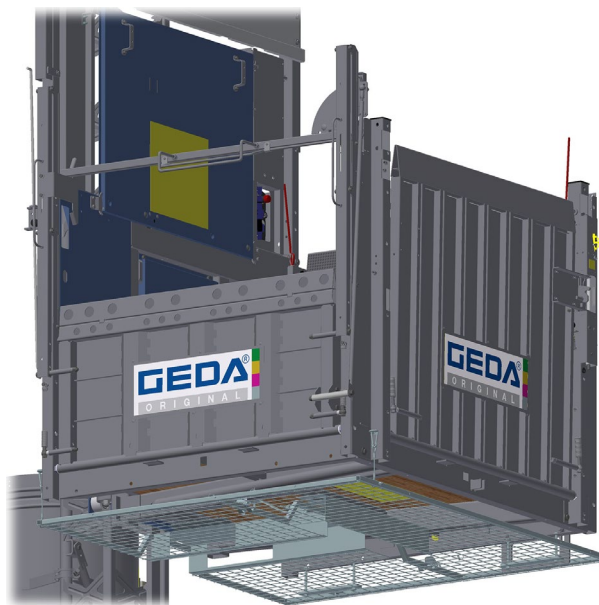

Fig. 65: Underrun protection



Fig. 66: Underrun protection platform SL



When the underrun protection is raised, control is interrupted by a limit switch. This only allows upward travel.

Remove the obstacle from the travel path. Only this allows travel again.

4.6.2 Cable bin cover

For better protection against theft, a cover can be installed on the cable bin for the trailing cable.

Assembly:

Assembly of the cable bin cover is described in separate instructions.

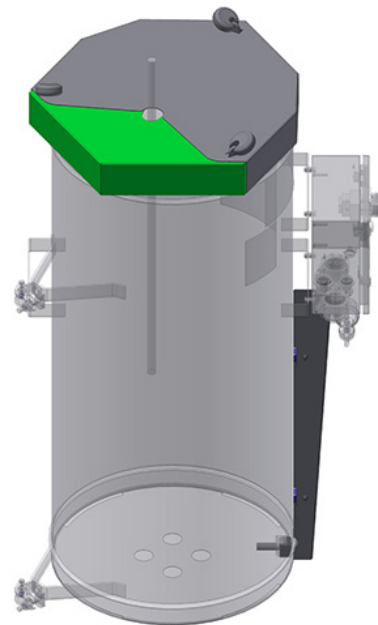

Fig. 67: Cable bin cover

4.6.3 Cold package

The 500 Z/ZP 2 can be used down to a temperature of $-20\text{ }^{\circ}\text{C}$. In countries where work is also carried out at lower temperatures, installation of a cold package is recommended.

A thermostat in the switch box of the platform switches off upward travel at temperatures below $-20\text{ }^{\circ}\text{C}$.



Fig. 68: Cold package

4.6.4 Mast assembly aid

The mast assembly aid can be used to easily lift or place mast parts onto the assembled mast.

Function:

For lifting and positioning mast sections during assembly/disassembly.



Fig. 69: Lifting, positioning of mast parts

4.6.5 Single axle trailer

A special single axle trailer is available for road transport of platforms A, B and C.

This single axle trailer can be fitted with a trailer coupling ring for cars or alternatively with a trailer coupling ring for lorries.





Fig. 70: Single axle trailer



Transport using a single-axle trailer is described in the separate operating manual supplied with this trailer.

5 Malfunctions – diagnosis – repair

⚠ WARNING	
	<p>Risk of injury from incorrect troubleshooting and fault elimination</p> <ul style="list-style-type: none"> ➤ Troubleshooting and the fault elimination may only be carried out by persons specially trained and authorized for this purpose. ➤ Before troubleshooting, lower the platform and unload it if possible! ➤ Immediately discontinue operation if faults occur that endanger operational safety!
⚠ DANGER	
	<p>Electric shock from live parts</p> <ul style="list-style-type: none"> ➤ Before working on the electrical system, switch off and lock the main switch. For safety reasons, disconnect the mains plug.

5.1 Diagnostic system

The diagnostic system allows quick and easy identification of the switching status of the limit switches and EMERGENCY STOP buttons.

After input of the travel command, only the green diode may light up. If this is not the case, the corresponding function or corresponding limit switch must be checked.

Switching states

green LED = standard **ON**
 yellow LED = standard **OFF**

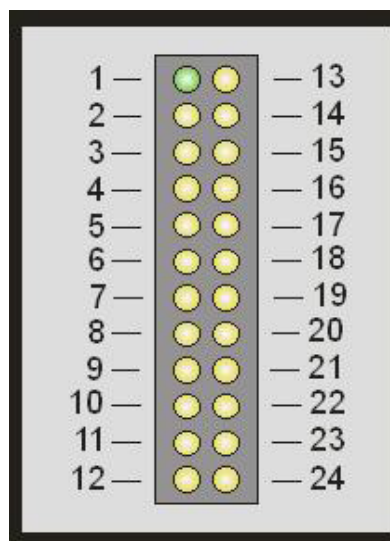

Fig. 71: Diagnostic system

LED no.	Meaning of the LED
1	Diagnostic system OK/READY/operation
2	Lights up when the EMERGENCY STOP button of the platform control is activated.
3	-
4	Lights up when the limit switch for the safety gear is activated.
5	Lights up when the UPPER or LOWER EMERGENCY LIMIT switch is activated.
6	Illuminates when the platform access to the building (barrier with loading ramp) is not locked.
7	-
8	Illuminates when the ground station platform access (double door/ramp) is not locked.
9	Lights up when the second (front) ground station platform access (double door/ramp) is not locked.
10	Lights up when the limit switch for the assembly guard is activated.
11	Lights up when the limit switch for the assembly plank is actuated.
12	-
13	Lights up when the limit switch of the underrun protection (1) is actuated.
14	-
15	Lights up when the UP limit switch is actuated.
16	Lights up when the DOWN limit switch is actuated.
17 - 24	-

5.2 Fault table

The following table lists potential malfunctions and the appropriate remedial action.

Malfunction	Cause	Remedial action
Green control light off		
	Mains plug disconnected	Connect the mains plug
	Mains switch off	Switch on the main switch
	Lamp defective	Replace lamp
	Phase failure	Measure the phases
	Incorrect phase sequence	Correct the phase sequence on the phase sequence monitor
	Travelling cable unplugged	Plug in the trailing cable
	Fuses in the ground station switch box not OK	Check/correction
Green control light lights up , platform does not move		
	EMERGENCY STOP button (at a control point) pressed	Unlock the EMERGENCY STOP button
	Loading door/ramp open	Close loading door/ramp
	Barrier with loading ramp open	Close barrier with loading ramp
	Assembly guard plate open	Attach assembly guard plate at the top
	Assembly plank (if fitted) open	Close the assembly plank and engage safety hook twice
	EMERGENCY LIMIT limit switch activated	Refer to platform moved too high/too low
	Base enclosure barrier / sliding door open (option)	Close the base enclosure barrier / sliding door
	Safety gear engaged	Release safety gear (see chapter 5.3.5 Safety gear has triggered)
	Key switch on the platform control switched to the incorrect operating mode	Activate control using key switch
Red control light lights up or pulsing signal tone sounds.		
	Overload protection has triggered	Reduce the load
Platform only moves upwards		
	Is the DOWN limit switch functioning properly	Check/replace the DOWN limit switch

Platform only moves upwards	
Is the UP limit switch functioning properly	Check/replace the UP limit switch
Clearance for the proximity switch for monitoring the gear rack is too large	Adjust the clearance to the gear rack (3 - 7 mm)
Platform moved too high (see chapter 5.3.2)	
Top landing level limit switch defective	Test/replace top landing level limit switch
Fault in the electrical system	Check system
Platform moved too low (see chapter 5.3.3)	
Fault in the electrical system	Check system
Air gap for the brake is too large	Adjust the air gap
Motor does not attain full performance	
Voltage drop of more than 10%	Select a supply cable or extension cable with a greater cross section
The platform access door at the ground station does not open.	
The platform was been stopped by the DOWN limit switch	Move the platform to the DOWN limit switch
Door lock defective	Door EMERGENCY release. Replace defective lock
No voltage	Connect power supply

5.3 Rectify fault

5.3.1 Motor is not delivering full power

- Voltage drop of more than 10% of the rated voltage.
- Select cable with larger cross-section.
- The integrated thermal switches turn off the control current when overloaded. Work can continue after a certain cooling down period (possibly reduce load).

⚠ CAUTION

Motor overload from overloading the machine

The motor heats up and the motor/brake service life is reduced.

5.3.2 Platform has travelled too high

The platform travels too high, i.e. the EMERGENCY limit switch of the platform reaches the **UP-END** stop rail.

Possible causes:

- the **UP** limit switch is defective
- there is a malfunction in the electrical system

Action:

- Bleed the motor brake using the brake release lever (see chapter 5.4.2 Rescue action plan).

5.3.3 Platform moved too low

The platform moves too low, i.e. the **EMERGENCY** limit switch of the platform reaches the lower **EMERGENCY STOP** stop rail.

Possible causes:

- brake clearance is too large
- the **DOWN** limit switch is defective
- there is a malfunction in the electrical system
- the platform is overloaded
- the platform was lowered with the manual brake release

Action:

- The platform has to be moved back to the operating range of the mast (clearance run).

⚠ CAUTION**Risk of injury from incorrect operation**

- Free movement using the drop test control may only be carried out by a competent person specifically appointed by the operating company who, due to their training, knowledge and practical experience, are able to evaluate the risks.

Drop test control

- Plug in the drop test control. (see chapter 5.3.5 Safety gear has triggered)
- From outside the platform, press the **UP** button (3).
- ✓ Now the platform moves out of the **END** position.

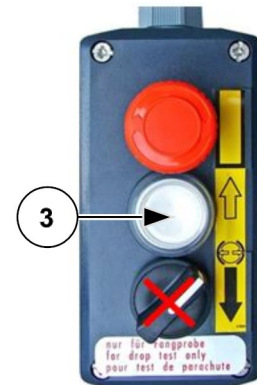

Fig. 72: Operating the drop test control

ATTENTION**Damage to the machine from incorrect operation**

- The **UP** button has to be pressed, as this control is used to bypass the **EMERGENCY** limit switch. If the rotary knob is activated inadvertently, the motor brake is released and the motor can drop hard onto the foot section.

- After neutral running, disconnect the drop test control and plug in the dummy plug.



If this problem occurs repeatedly despite the platform not being overloaded, have the brake checked or adjusted by a qualified person.

5.3.4 Overload detection device has triggered

The platform is equipped with an overload detection device which prevents the platform from being operated when it is overloaded.

If the platform is overloaded, the red control light on the platform lights up.

- Reduce the load weight on the platform until the red control light (8) goes out. - Only then is travel possible.

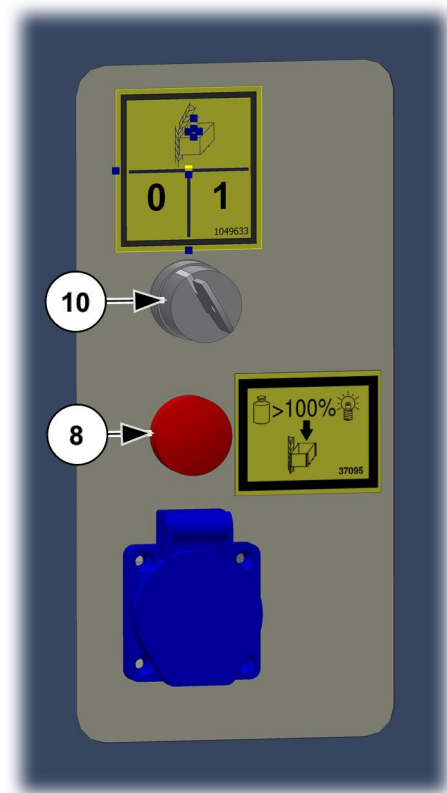

Fig. 73: Overload indicator

5.3.5 Safety gear has triggered

The platform is equipped with safety gear that slows down the platform if it travels too fast. Further travel is not possible once the safety gear has been triggered.

⚠ WARNING



Risk of death from the safety gear being triggered

- All persons must exit the platform.
- Determine why the safety gear has engaged, secure the platform and repair the damage before releasing the safety gear!
- The safety gear may only be released by a competent person who is specifically appointed by the operating company and who, due to their training, knowledge and practical experience, are able to evaluate the risks and assess the safe condition of the safety gear.

- Remove the dummy plug (1).
- Insert the drop test control into the plug connection (2) below the switch box of the trolley.

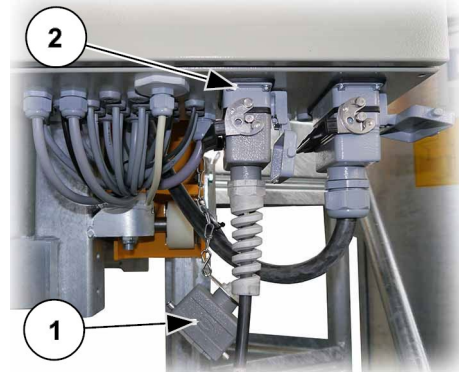

Fig. 74: Dummy plug for drop test control

- Press the button (3) from outside the platform and move the platform up by approx. 20 - 30 cm.
- After the clearance run, disconnect the drop test control again and plug in the dummy plug (1) on the plug-in connection (2).

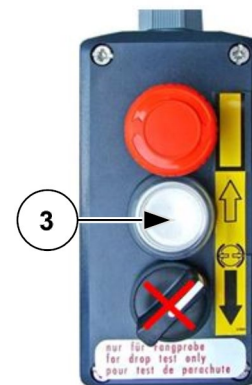

Fig. 75: Drop test control

- Release the lock nut (4) on the safety gear.
- Rotate the safety-gear protective cover (5) to the left until the limit switch lug (6) engages in the slot of the protective cover.
- Fully tighten the lock nut.

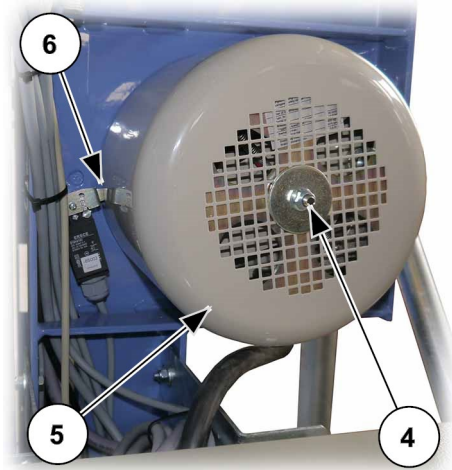

Fig. 76: Safety gear with limit switch



After the safety gear was activated, it must be inspected for signs of damage. The inspection, which must be carried out by a competent person, is described in the Maintenance Manual.

5.4 Retrieving the platform

Rescue may become necessary in the event that, e.g.

- there is no mains voltage.
- the electrical system malfunctions.
- the drive has failed.
- the safety gear has triggered.



If the supervisor/platform operator does not feel confident or qualified to organise and carry out the rescue, notify the relevant authorities (rescue personnel).

5.4.1 Basic conduct in the event of a rescue/malfunction

- Obtain an overview of the situation.
- Remain calm and do not act hastily.
- Be cautious and thorough when checking the situation!
 - Is anybody hurt?
- Keep unauthorised persons away.
- Contact any persons trapped in the car.
- Attempt to find the cause of the malfunction/defect on the system, e.g.
 - power failure
 - safety gear triggered
- If necessary, inform the trapped persons about the planned procedure.
- Notify your supervisor about the malfunction.
- Notify any rescue services.



The sequence of measures can/must be amended by the attendant/rescue personnel depending on the specific situation.

5.4.2 Rescue action plan

Action 1: Check the operating mode.

The LED display (7) must illuminate when the platform control is active!

- In the event that the LED display (7) does not illuminate, the platform control must be activated at the key switch (5).
- Briefly rotate the key to the right to activate the platform control.
- Release the key.

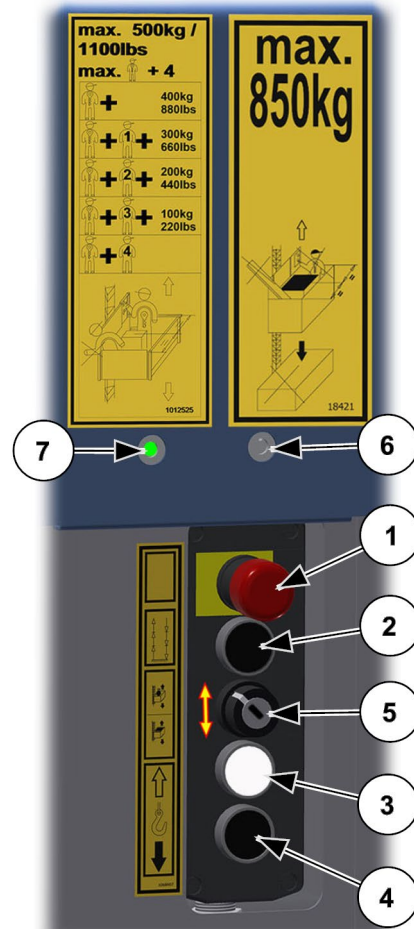

Fig. 77: Platform control/transport platform operation

Action 2: Self-rescue using the EMERGENCY descent function.**Triggering of the safety gear**

In order to prevent the safety gear engaging, the brake release lever has to be operated with extreme caution. Once the safety gear has engaged, the platform can no longer be moved and has to be lifted. See chapter 5.3.3 Platform moved too low

The EMERGENCY descent function is used only in an emergency to reach the next lower landing level. Persons trapped may be able to evacuate themselves in this way.

It must not be used for lowering the platform during operation!

- Take the brake release lever (1) from the mounts (2) and screw into the brake through the label (Brake Indicator).

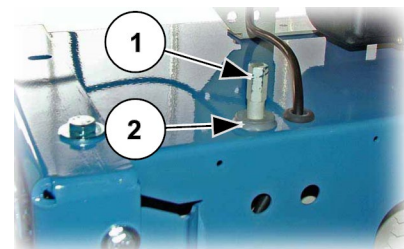

Fig. 78: Mount for brake release lever

**The label (Brake Indicator) will be damaged during emergency release and has to be replaced after checking the motor brake!**

- Release motor brake by controlled pulling on the brake release lever (1).
- The platform glides downwards.

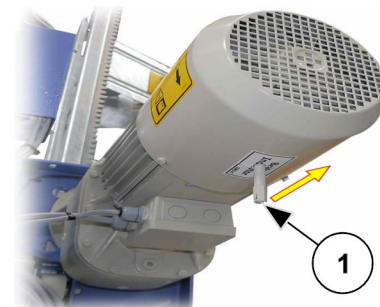

Fig. 79: Pulling on the brake release lever

⚠ CAUTION

The brake becomes very hot and loses braking power

- Interrupt the lowering process for 2 min after every 1 - 2 m at the latest. The length of a mast section can be used for orientation.
- When at the next landing level, release the brake release lever.
- Stop so that the floor of the platform is slightly above the sill of the landing level safety gate.
- Exit the platform.



It is not possible to lower the platform by releasing the motor brakes if e.g. the safety gear has been triggered.

⚠ WARNING

Risk of injury from defective safety gear

- Now check to ensure that no parts of the drive system are broken, damaged or unserviceable. In this case, the safety gear must **not** be released.
- **The transport platform must be decommissioned!**

After the emergency:

After emergency lowering, the motor brake has to be checked (e.g. check brake path, see Maintenance Manual).

- Place the brake release lever (1) back in the bracket (2)
- Replace the damaged label (brake indicator) or place a new label over it.

Action 3: Rescue in accordance with the emergency/rescue plan of the operating company.



An emergency/rescue plan must be prepared by the operating company and kept in a clearly visible place on the transport platform!

5.5 Repair

ATTENTION

**Maintenance work carried out by untrained personnel**

- Repair work may only be carried out by trained and competent persons because it requires special expert knowledge and skills. Neither is explained in this Operating Manual.

When ordering spare parts, please provide the following:

- Type
- Year of construction
- Factory no.
- Operating voltage
- Quantity required

The name plate is located on the trolley of the base unit.



Spare parts must conform to the manufacturer's technical specifications! Only use original spare parts from GEDA.

For service or repair work, please contact our customer service department:

For the sales and customer service address, see chapter 1.4
Manufacturer's name and address

6 Disposal

At the end of its useful life, the machine may need to be inspected for operational safety in accordance with national regulations, disassembled correctly and scrapped in an environmentally friendly way according to national provisions.



It is prohibited to use parts from a machine that is being scrapped in other machines or to assemble such parts to produce a new machine.

During disposal of the machine components, observe the following:

- Drain and dispose of oil/grease in an environmentally friendly way.
- Recycle metal parts.
- Recycle plastic parts.

Recommendation:

Contact the manufacturer or commission a specialist company to handle disposal requirements in accordance with the applicable regulations.



GEDA-Dechentreiter GmbH & Co. KG

Mertinger Strasse 60

86663 Asbach-Bäumenheim

Tel.: +49 (0)9 06 / 98 09-0

Fax: +49 (0)9 06 / 98 09-50

E-Mail: info@geda.de

Web: www.geda.de

BL145 GB 2019-05